

aerospace
climate control
electromechanical
filtration
fluid & gas handling
hydraulics
pneumatics
process control
sealing & shielding

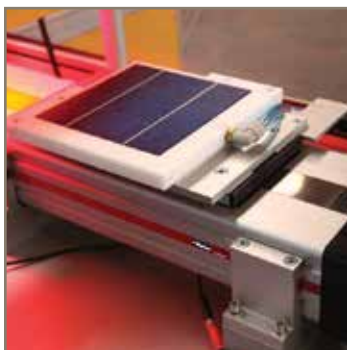

OSPE Origa System Plus

Belt-Driven and Screw-Driven
Modular Electric Actuators

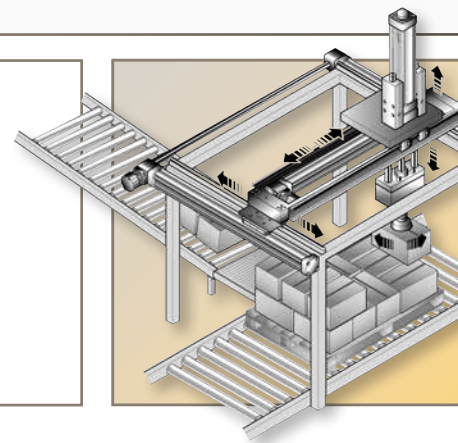

ENGINEERING YOUR SUCCESS.

OSPE Series Actuators

Parker Origa System Plus (OSPE) Series electric motor-driven actuator systems are field-proven worldwide.

OSPE Actuator systems are completely modular to accommodate a broad range of application installation and performance requirements. Compact size, maximum configurability and the flexibility to select the right drive train technology for high speed and/or precise positioning applications makes the OSPE easy to integrate into any machine layout simply and neatly.

All OSPE Actuators feature an extruded aluminium profile with dual dovetail slots on three sides for direct mounting of a variety of hardware options. Developed for absolute reliability, high performance, easy handling and optimized design flexibility, OSPE Actuators meet the most critical application requirements.

- **Belt-driven actuators recommended for long strokes, dynamic movements and high speed requirements in point to point applications**
- **Screw-driven actuators recommended for medium precise positioning, high thrust force output and zero backdrive in intermittent positioning applications**
- **External bearing options recommended to increase the over all load capability and system stiffness in most demanding applications**
- **Design configurability supporting flexible designing processes and offer easy selection criteria to meet individual machine requirements**



OSPE Series actuators are available in a range of belt-driven and screw-driven configurations that accommodate an extremely wide spectrum of load, speed and stroke requirements.

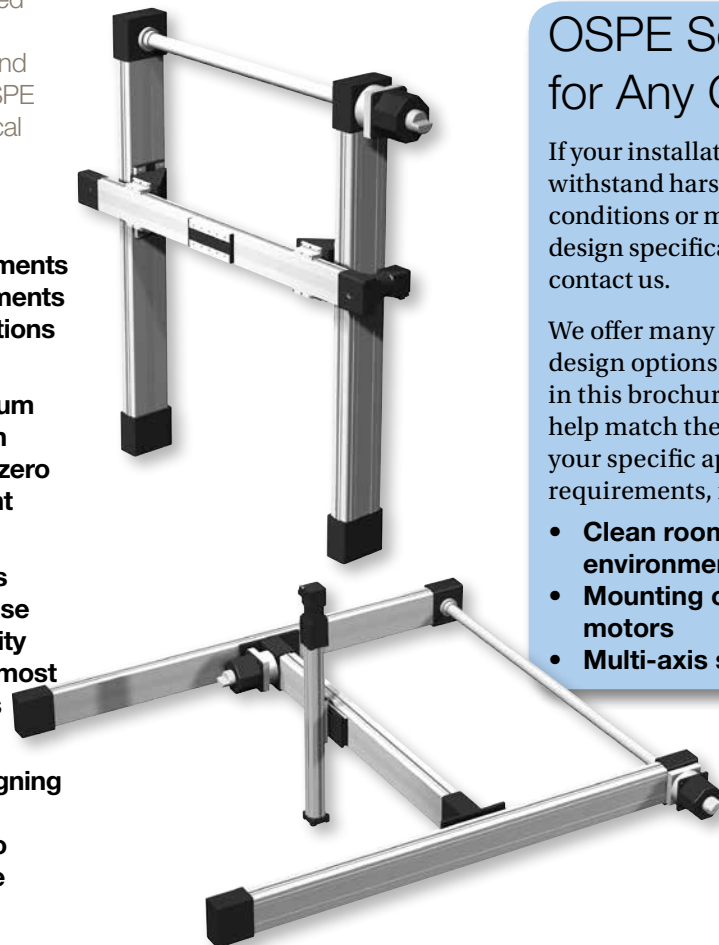

OSPE Solutions for Any Condition

If your installation needs to withstand harsh environmental conditions or meet a critical design specification, please contact us.

We offer many non-standard design options not covered in this brochure that will help match the OSPE to your specific application requirements, including:

- **Clean room or harsh environments**
- **Mounting of customer motors**
- **Multi-axis systems**



Table of Contents

Applications and Selection Overview

4 – 9 OSPE Actuators are used in a wide range of material handling and machine automation functions; choose the OSPE Series with the features and performance best suited to your application requirements.

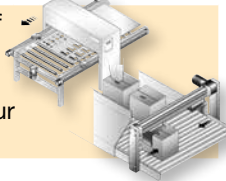

OSPE..BHD

10 – 27 Belt-driven actuator with integrated ball bearing or roller guide for heavy duty applications

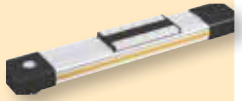

OSPE..B

28 – 49 Belt-driven actuator with internal glider bearing for long strokes and high speed applications

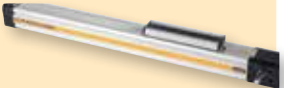

OSPE..SB/ST

50 – 73 Screw-driven actuator with internal glider bearing for precise positioning with a ball screw or zero backdrive with a trapezoidal screw

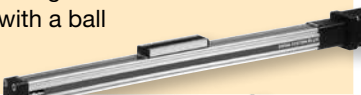

OSPE..BV

74 – 79 Belt-driven cantilever actuator with integrated ball bearing guide

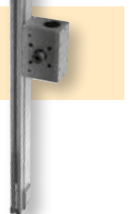

Free Access Sizing and Selection Software...

Use Parker EL Sizing software to expedite your sizing and selection processes. The program is free and can be downloaded from our website.

Visit www.parkermotion.com to download the latest version.



Free Download CAD Drawings

Take advantage of our online CAD platform and easily integrate any configuration to accelerate your designing process.

Visit www.parkermotion.com, to download your individual configuration.

If you don't find exactly what you are looking for in this brochure, please contact us for information on additional OSPE configurations, other suitable Parker products, and to discuss your requirements with an application engineer.



Need more Information? Visit our Website...

Complete up-to-date technical assistance can be found on the web at www.parkermotion.com. This includes all the latest information on current products, new product introductions, local assistance and support, plus a comprehensive "Engineering Reference Library" including: complete product catalog data, product selection Wizards, performance charts and graphs, engineering data and calculations, CAD drawings, local service and support directory, on-line purchasing, application stories and videos.

OSPE Series Actuators

Versatile Performance for Diverse Application Capabilities

Measuring Systems

Synchronized bi-parting actuation for optical curvature gauging

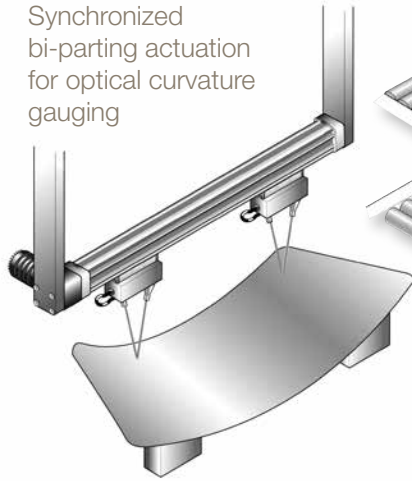

Conveyors

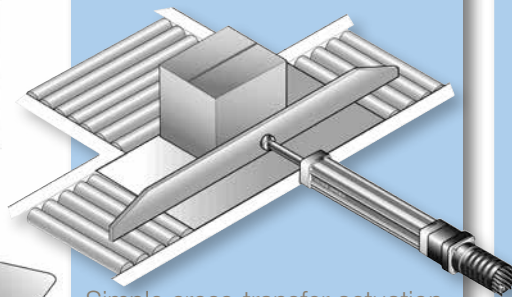

Simple cross-transfer actuation

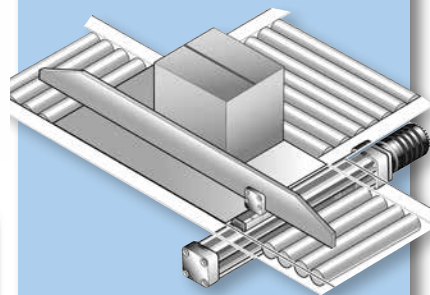

Centering packages

Material Handling

Parallel actuation for a vertical lift on a mechanical material handling system

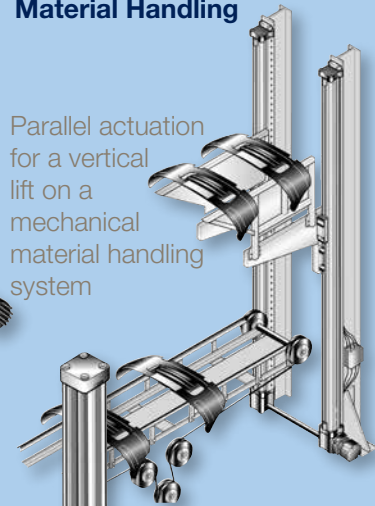

Self-contained mobile lift

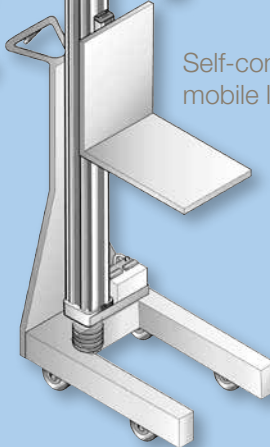

Vertical and horizontal transfer movements

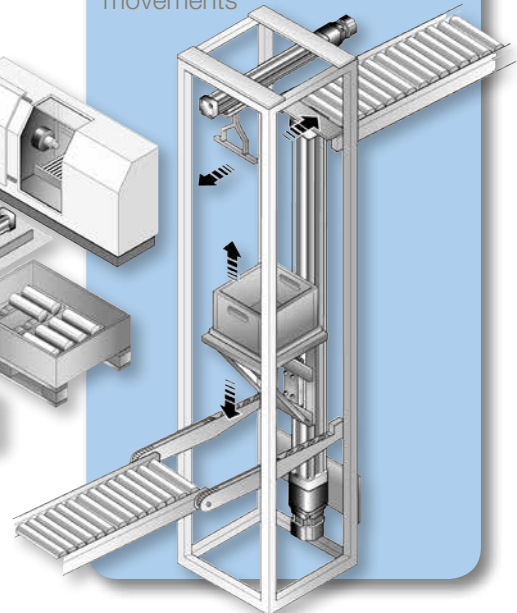

Automated Handling

High speed pick and place gantry

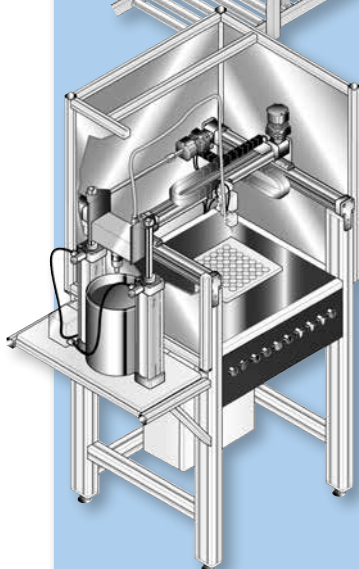
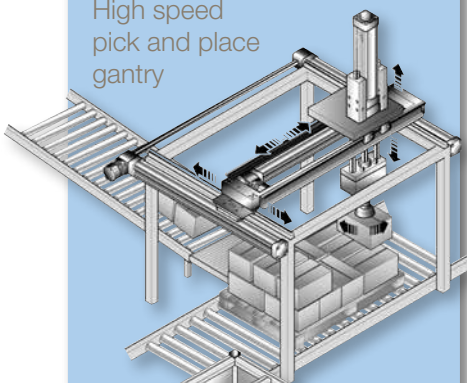

Accurate 3-axis positioning for automated filling process

Robotics

Robot traverse between workstations

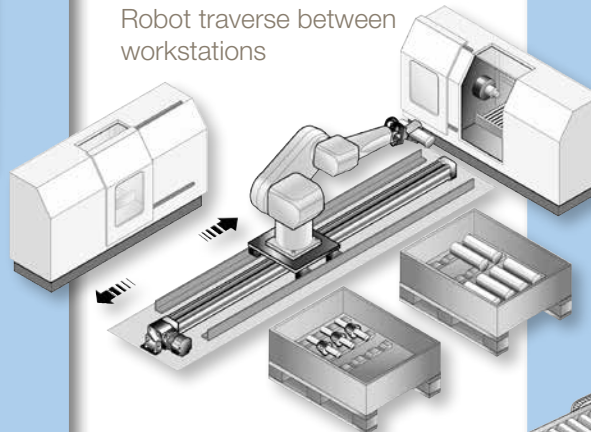

Ergonomic Adjustment

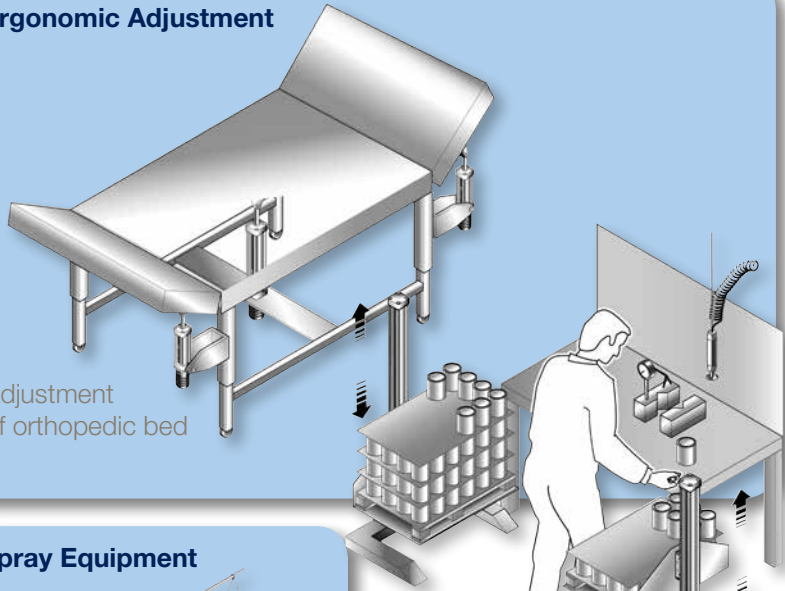

Adjustment of orthopedic bed

Work level adjustment of workstation

Opening and Closing Operations



Simple bi-parting operation for automatic doors and guards

Adjustment of air dampers on ventilation system

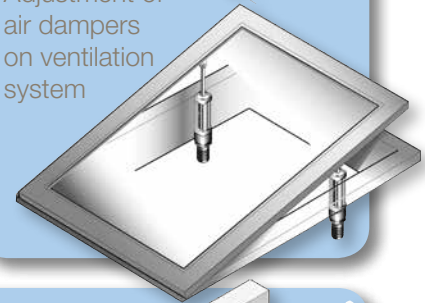

Spray Equipment

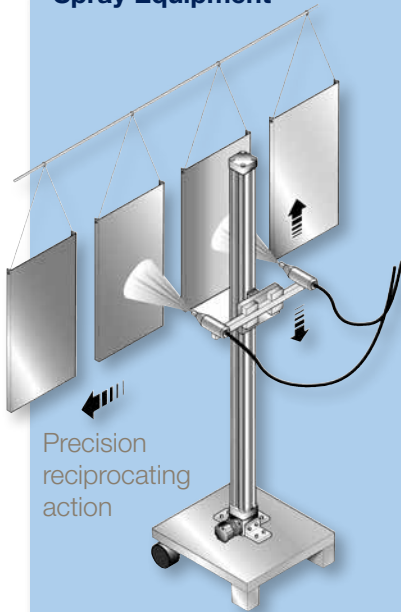

Precision reciprocating action

Synchronized high speed bi-parting movements for spray coating operation

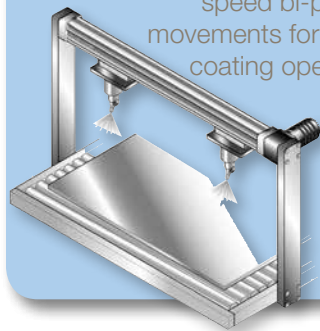

Machining Functions

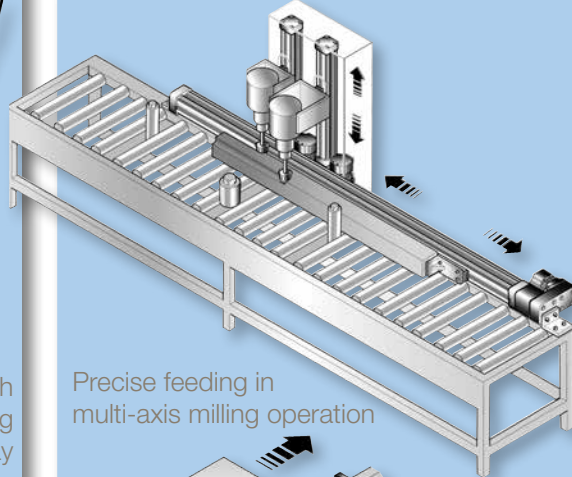

Precise feeding in multi-axis milling operation

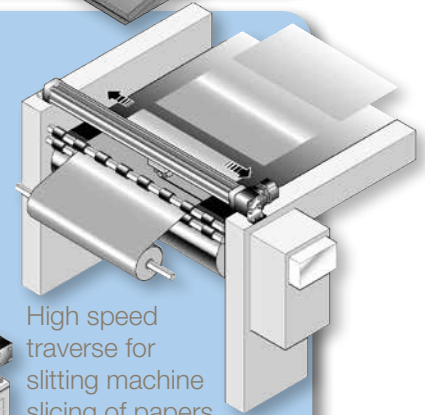

High speed traverse for slitting machine slicing of papers and textiles

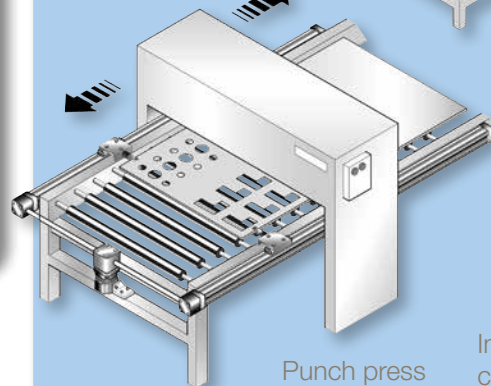

Punch press accurate feeding and positioning

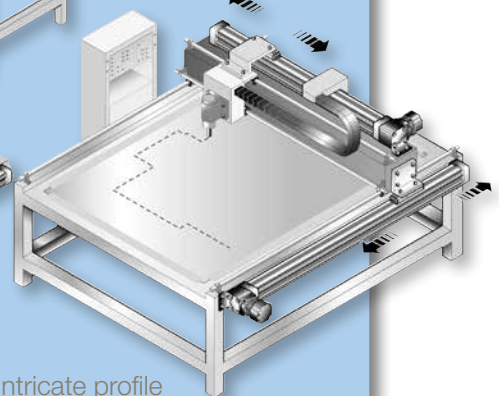

Intricate profile cutting movements of water jets and lasers

OSPE Series Actuators

Sizing/Selection Overview At-a-Glance

Use the procedure outlined below to pre-select the OSPE product series based on an application's key performance data; speed (or stroke and move time), acceleration and thrust force. Once the pre-selection is completed the user can refer to the relevant product section for more detailed performance information.

1 Specify actuator orientation, stroke, load and move time

To start the pre-selection process, actuator orientation, load, stroke and move time must be determined. The actuator orientation is typically either horizontal or vertical. The load [m] is the overall weight in kilograms that is mounted to the carriage. The stroke [d] is the distance in meters the load travels. Lastly, the move time [t] is the time in seconds that it takes to move the load the entire stroke.

2 Calculate speed and acceleration

A good starting point is to use either a trapezoidal or triangular motion profile to calculate required speed and acceleration. The equations provided below assume that the acceleration and deceleration rates are equal but opposite.

For example, an actuator mounted in a vertical orientation moves an 8 kilogram load 1 meter in 0.75 seconds. Assuming a trapezoidal motion profile with the acceleration time, constant speed time and deceleration time all equal to 1/3 of the total move time, the maximum calculated speed is 2.0 m/s with an acceleration of 8.0 m/s².

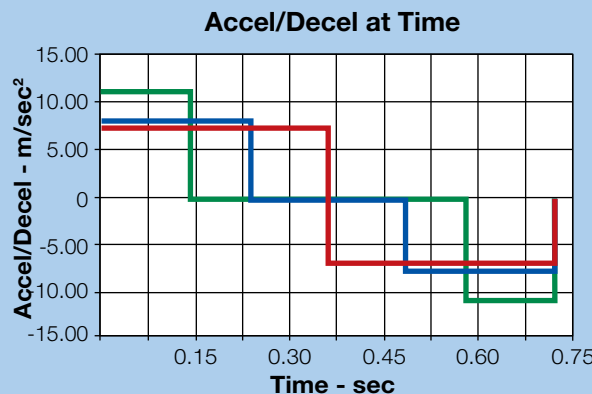
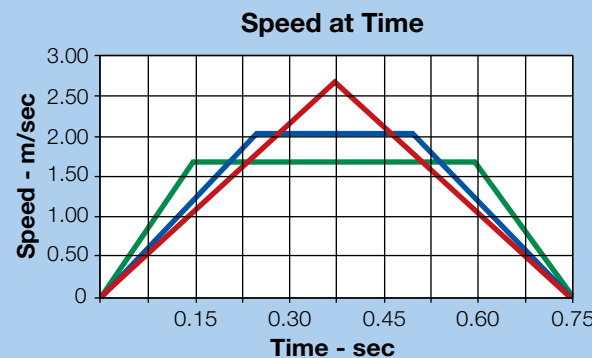
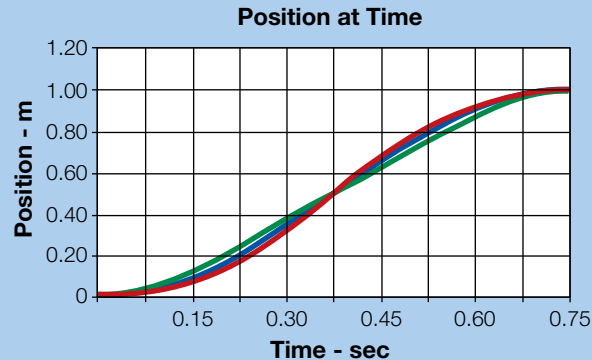

Triangular Motion Profile:

$$vt/2 = 2.00 * d/t$$
$$a = 4.00 * d/t^2$$

Trapezoidal Motion Profile:

$$vt/3 = 1.50 * d/t$$
$$a = 4.50 * d/t^2$$

Trapezoidal Motion Profile:

$$vt/5 = 1.25 * d/t$$
$$a = 6.25 * d/t^2$$

3 Calculate thrust force

The calculation of thrust force is calculated using the actuator orientation and required acceleration (calculated above) of the load that is being moved. Additional forces such as the losses due to friction need to also be considered, but can wait until the product series is defined.

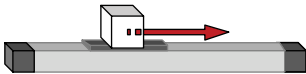

Horizontal actuator orientation:

$$F_x = F_a * F_{\mu} = m * a + m * g * \mu$$

Vertical actuator orientation*:

$$F_x = F_g * F_a = m * g + m * a$$

Due to gravity in the vertical orientation, the maximum required thrust force $F_x = 142.5 \text{ N}$

$$F_x = 8 \text{ kg} * 9.81 \text{ m/s}^2 + 8 \text{ kg} * 8.00 \text{ m/s}^2 = 142.5 \text{ N}$$

*For vertical actuation applications, please consider the BV Series vertical actuators, page 74.

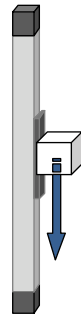

4 Select the appropriate product series



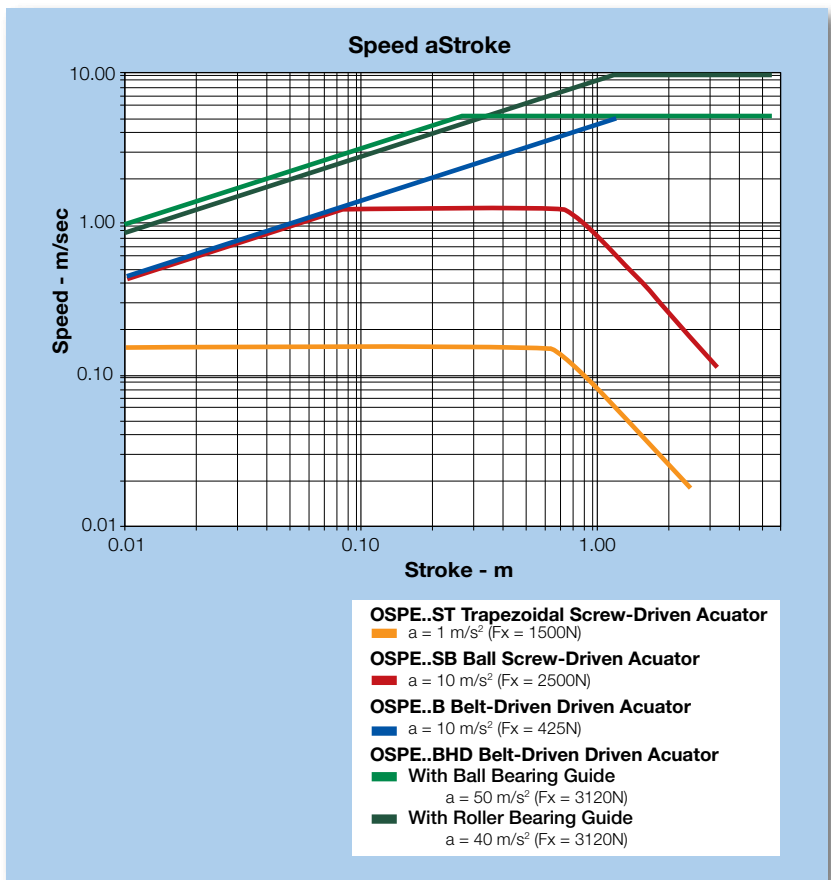

Draw a line for required speed and stroke, to find out which actuators are suitable for the given application data. The OSPE..B series can handle stroke of $d_s = 1.0 \text{ m}$ and speed of $v_t/3 = 2.0 \text{ m/s}$ as well as an acceleration of $a_t/3 = 8.0 \text{ m/s}^2$ and thrust force $F_x = 142.5 \text{ N}$, and therefore would be the best choice to start with.

Now a closer look to the right product series section will help to determine the correct actuator profile size using the normal load, moment loads and required input torque for motor sizing.



OSPE Series Actuators

Product Overview At-a-Glance

		OSPE Belt-Driven Actuators						
		Design Series	OSPE..BHD (Belt - Heavy Duty) Page 10				OSPE..BV (Belt - Vertical) Page 74	
			Actuator Size	20	25	32	50	20
Thrust Force – N (lbs)		550 (124)	1070 (241)	1870 (420)	3120 (701)	650 (146)	1430 (321)	
Maximum Linear Speed – m/s (in/s)		3 (118)	5 (197)* 10 (394)**	5 (197)* 10 (394)**	5 (197)* 10 (394)**	3 (118)	5 (197)	
Maximum Acceleration – m/s² (in/s²)		50 (1969)	50 (1969)* 40 (1575)**	50 (1969)* 40 (1575)**	50 (1969)* 40 (1575)**	20 (787)	20 (787)	
Repeatability – μm		±50	±50	±50	±50	±50	±50	
Maximum Order Stroke Length ⁽¹⁾ – mm (in)		5760 (227)	5700 (225)	5600 (220)	5500 (216)	1000 (39)	1500 (59)	
Ambient Temperature – °C		-30 to 80	-30 to 80	-30 to 80	-30 to 80	-30 to 80	-30 to 80	
Protection Class		IP 54	IP 54	IP 54	IP 54	IP 20	IP 20	
Maximum Load N (lbs)	Standard Carriage	1600 (360)	3000 (674)* 986 (222)**	10000 (2247)* 1348 (303)**	15000(3370)* 3704 (832)**	1600 (360)	3000 (674)	
	With ProLine	–	–	–	–	–	–	
	With PowerSlide	–	–	–	–	–	–	
Xpress Motor and Gearhead Options ⁽²⁾	 Motor Mounting Kit	–	–	–	–	–	–	
	 Gearhead Mounting Kit	•	•	•	•	•	•	
	 Mounted Gearhead w/Motor Mounting Kit	•	•	•	•	–	–	
	 Mounted Motor	•	•	•	•	–	–	
	 Mounted Gearhead and Motor	•	•	•	•	–	–	
Standard Design Options	Standard Carriage	•	•	•	•	•	•	
	Tandem Carriage	•	•	•	•	•	•	
	Bi-parting Carriage	•	•	•	•	–	–	
	Standard Motor Mounting Kit	•	•	•	•	–	–	
	ProLine and PowerSlide	–	–	–	–	–	–	
	External Linear Guides	–	–	–	–	–	–	
	End Cap Mounting	•	•	•	•	–	–	
	Profile Mounting	•	•	•	•	–	–	
	Clevis Mounted Carriage	–	–	–	–	–	–	
	Inversion Mounted Carriage	–	–	–	–	–	–	
Magnetic Position Sensors	•	•	•	•	•	•		

* Ball bearing guide models ** Roller guide models ⁽¹⁾ Longer lengths available - consult factory

⁽²⁾ Xpress system options are pre-assembled configurations using performance matched Parker gearheads and motors

OSPE..BHD Belt-Driven Actuators

Actuators for High-Speed, Long Travel, Heavy Duty Applications

The OSPE..BHD is the highest capacity belt-driven actuator in the OSPE family. The integrated ball bearing guide or optional roller guide are proven in thousands of industrial machines requiring robustness, dynamic precision and extraordinary performance with an aesthetically pleasing design.

The compact design allows integration of the OSPE..BHD in any machine layout, providing very little space, without sacrificing payload or thrust capacity.

Advantages:

- High dynamic for precision positioning
- High thrust capacity
- High payload capacity
- High speed operation
- Easy installation
- Ideal in multi axis applications

Features:

- Integrated ball bearing guide or roller guide
- Clamp drive shaft design for compact and backlash free gearhead and motor mounting
- Tandem carriage with second carriage for higher load capabilities
- Long available strokes
- Complete motor and drive packages
- Bi-parting carriages and special options on request
- Ambient temperature range -30°C to +80°C
- IP 54 Rating

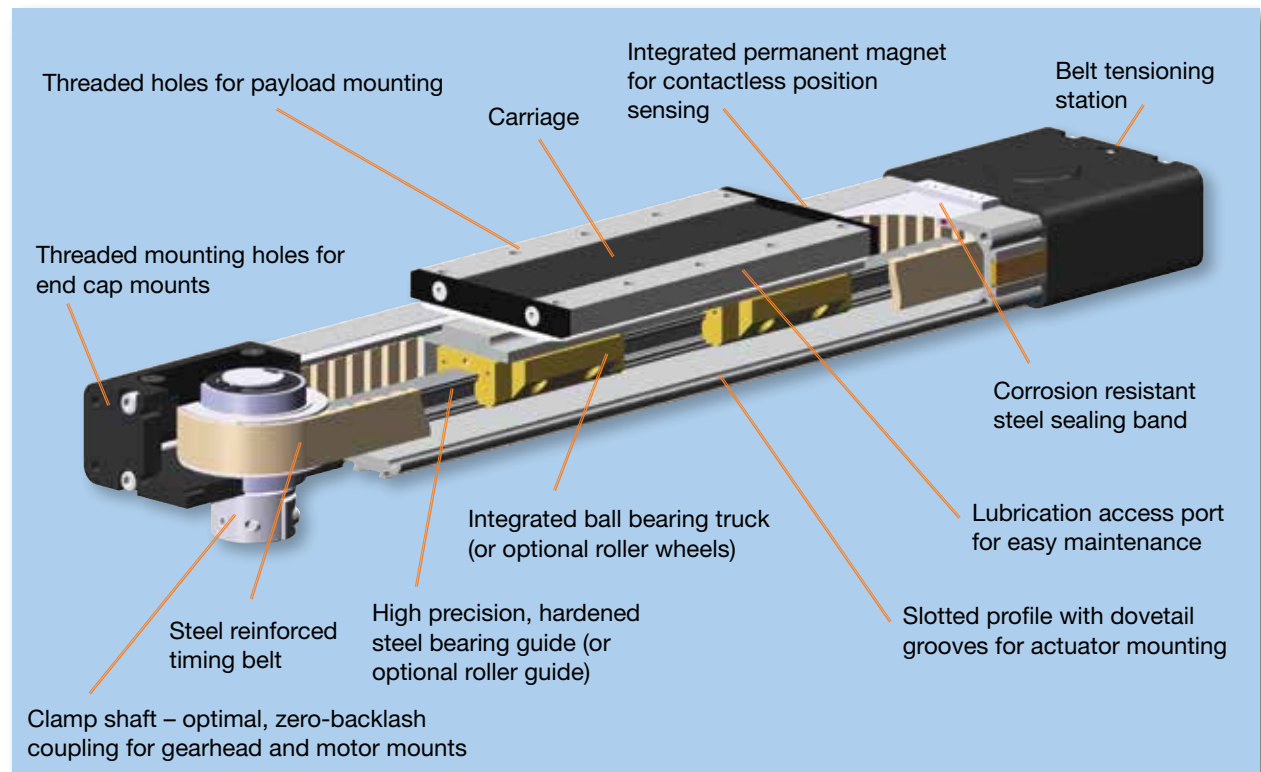

Choose from a Wide Range of Standard Options for Maximum Design Flexibility in a Pre-assembled Solution

Integrated Bearing Design



Ball bearing - with a high-precision, hardened-steel rail and calibrated bearing trucks for high load capabilities



Roller bearing - with in aluminum grounded and calibrated steel track and needle bearing wheels for high-speed operation up to 10 m/s.

Drive Shaft Options

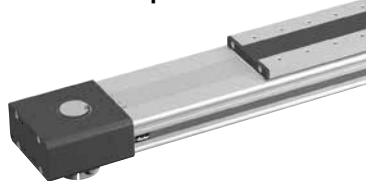

Clamp shaft — for zero-backlash coupling



Plain shaft — for dual axis linking



Clamp and plain shaft — for master unit to connect link shaft on plain shaft



Hollow shaft - for compact gearhead mounting

Actuator Mounting Options



End cap mounting — allows the actuator to be anchored by the end caps



Profile mounts — support long travel actuators or for direct mounting

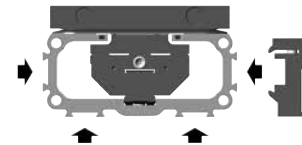

Carriage Options



Standard carriage

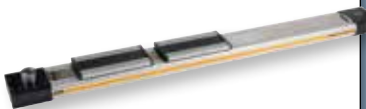

Tandem carriage — for higher load capabilities



Bi-parting carriage — for opposing synchronized movements

Multi-axis Systems



A wide range of adapter plates and intermediate drive shafts simplifies engineering and installation.

Please consult factory for your individual system design.

Options and Accessories



Information on all OSPE..BHD Series options is detailed on the following pages. Simply select all the options needed to solve your application requirements, then order with the actuator using convenient order codes (see last pages of the OSPE..BHD section). To order an option separately as an upgrade to an existing system or as a replacement part, use the individual option part numbers provided.

OSPE..BHD Belt-Driven Actuators

General Specifications

Actuator Size			OSPE20BHD	OSPE25BHD	OSPE32BHD	OSPE50BHD			
Integrated Guide Rail ⁽¹⁾			B	B	R	B	R		
Travel Distance per Revolution	s_{lin}	mm	125	180	180	240	240	350	350
		mm	39.79	57.30	57.30	76.39	76.39	111.41	111.41
Linear Speed (Max)	v_{max}	m/s	3	5	10	5	10	5	10
Acceleration (Max)	a_{max}	m/s ²	50	50	40	50	40	50	40
Repeatability (unidirectional)		μm	± 50	± 50	± 50	± 50	± 50	± 50	± 50
Order Stroke (Max) ⁽²⁾		mm	5,760	5,700	5,700	5,600	5,600	5,500	5,500
Thrust Force (Max)	F_{Amax}	N	550	1,070	1,070	1,870	1,870	3,120	3,120
		lbs	124	241	241	420	420	701	701
Torque on Drive Shaft (Max)	M_{Amax}	Nm	12	32	32	74	74	177	177
		in-lb	102	282	282	652	652	1,567	1,567
Torque ⁽³⁾ — RMS No Load	M_0	Nm	0.9	1.4	1.4	2.5	2.5	4.2	4.2
		in-lb	8	12	12	22	22	37	37
Torque ⁽³⁾ — Peak No Load	M_0	Nm	1.1	1.9	1.9	3.2	3.2	6.0	6.0
		in-lb	10	17	17	28	28	53	53
Load ⁽⁴⁾ (Max)	F_Y	N	1,600	2,000	986	5,000	1,348	12,000	3,704
		lbs	360	450	222	1,124	303	2,698	833
	F_Z	N	1,600	3,000	986	10,000	1,348	15,000	3,704
		lbs	360	674	222	2,248	303	3,372	833
Bending Moment Load ⁽⁴⁾ (Max)	M_X	Nm	21	50	11	120	19	180	87
		in-lb	186	443	97	1,062	168	1,593	770
	M_Y	Nm	150	500	64	1,000	115	1,800	365
		in-lb	1,328	4,425	566	8,851	1,018	15,931	3,231
	M_Z	Nm	150	500	64	1,400	115	2,500	365
		in-lb	1,328	4,425	566	12,391	1,018	22,127	3,231
Inertia									
@ Zero Stroke	J_0	kgmm ²	280	1,229	984	3,945	3,498	25,678	19,690
Per Meter of Stroke	J_{OS}	kgmm ² /m	41	227	227	496	496	1,738	1,738
Per 1 kg Moved Mass	J_m	kgmm ² /kg	413	821	821	1,459	1,459	3,103	3,103
Weight									
@ Zero Stroke	m_0	kg	2.0	2.8	2.8	6.2	5.8	18.2	17.9
Per Meter of Stroke	m_{OS}	kg/m	4.0	4.5	4.3	7.8	6.7	17.0	15.2
Carriage	m_C	kg	0.8	1.5	1.0	2.6	1.9	7.8	4.7
Ambient Temperature Range		°C	-30 to +80						
IP Rating)			IP 54						

⁽¹⁾ B = Ball Bearing Guide Rail; R = Roller Guide

⁽²⁾ Longer, extended order strokes on request OSPE20BHD = 6000 mm; OSPE25BHD = 9400 mm; OSPE32BHD = 9200 mm

⁽³⁾ For tandem and bi-parting options double the values listed.

⁽⁴⁾ Load and bending moment based on 8000 km performance

Available Thrust Force by Speed and Stroke

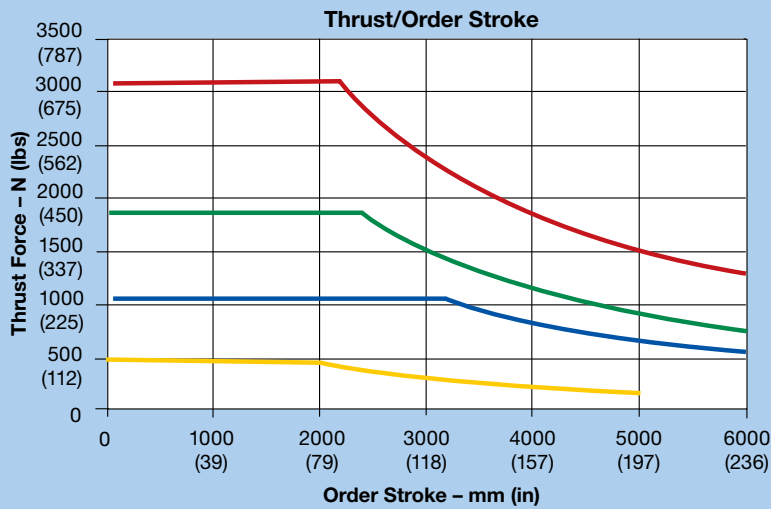
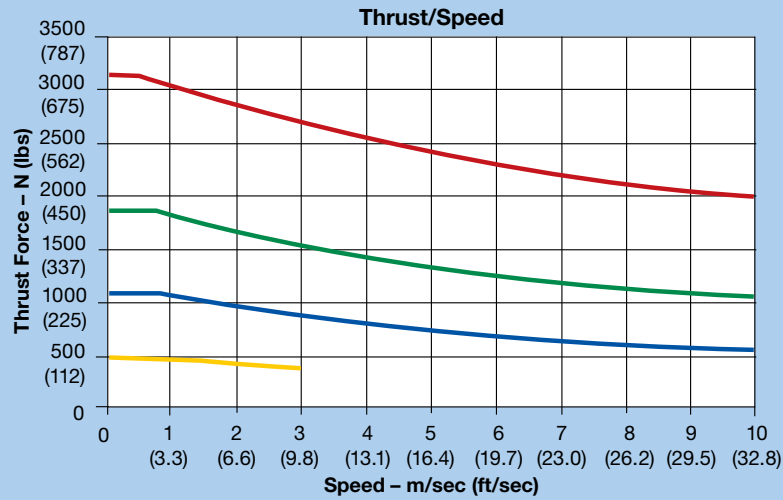

— OSPE20BHD — OSPE25BHD — OSPE32BHD — OSPE50BHD

Calculating Load Factors - Combined Normal and Moment Load

The sum of combined loads (static and dynamic) must not exceed "1" at any time as shown in the formula below:

$$\frac{F_z}{F_z(\max)} + \frac{M_x}{M_x(\max)} + \frac{M_y}{M_y(\max)} + \frac{M_z}{M_z(\max)} \leq 1$$

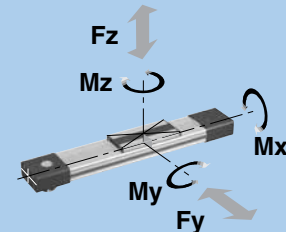

$M = F \times l$ (Nm)
 $M_x = M_{x \text{ static}} + M_{x \text{ dynamic}}$
 $M_y = M_{y \text{ static}} + M_{y \text{ dynamic}}$
 $M_z = M_{z \text{ static}} + M_{z \text{ dynamic}}$

OSPE..BHD Belt-Driven Actuators

Dimensions — mm



Standard Carriage

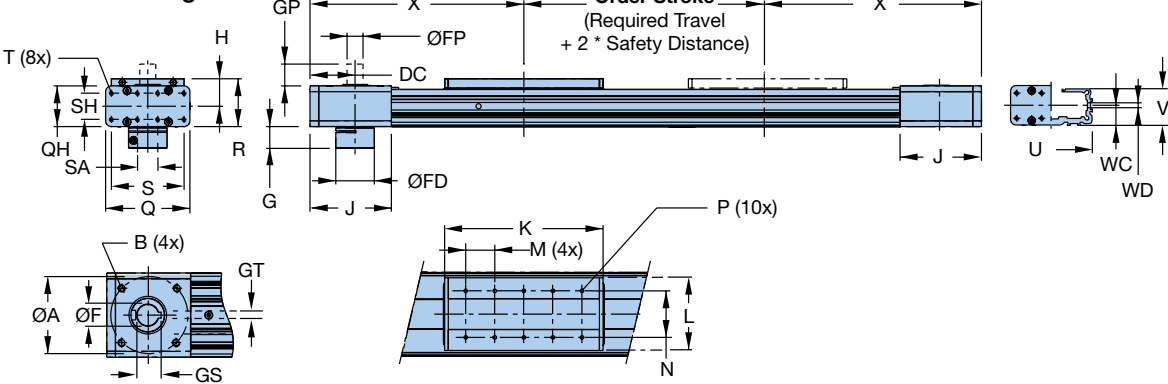

Tandem Carriage

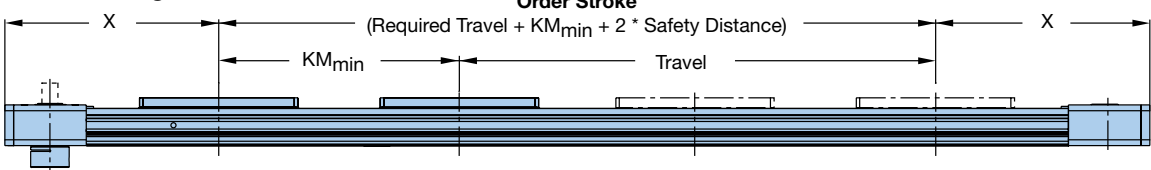

Bi-Parting Carriage

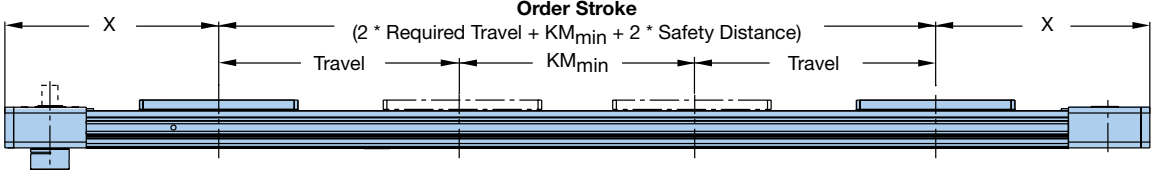

Dimensions — mm

Actuator Size	A	B	DC	F	FD	FP	G	GP	GS	GT
OSPE20BHD	65.7	M6x8	42.5	12 ^{H7}	27	12 _{h7}	18.0	25	13.8	4
OSPE25BHD	82.0	M8x8	49.0	16 ^{H7}	34	16 _{h7}	21.7	30	18.3	5
OSPE32BHD	106.0	M10x12	62.0	22 ^{H7}	53	22 _{h7}	30.0	30	24.8	6
OSPE50BHD	144.0	M12x19	79.5	32 ^{H7}	75	32 _{h7}	41.0	35	35.3	10

* For OSPE50BHD with roller guide: Dimension K = 263

Actuator Size	H	J	K	L	M	N	P	Q	QH
OSPE20BHD	27.6	76.5	155	67	30	51	M5x8	73	38
OSPE25BHD	31.0	88.0	178	85	40	64	M6x8	93	42
OSPE32BHD	38.0	112.0	218	100	40	64	M6x10	116	56
OSPE50BHD	49.0	147.0	288*	124	60	90	M6x10	175	87

Actuator Size	R	S	SA	SH	T	U	V	WC	WD	X
OSPE20BHD	49.0	60	18	27	M5x8.5	73	36.0	21.1	10.4	185
OSPE25BHD	52.5	79	25	27	M5x10	92	39.5	21.5	10.4	218
OSPE32BHD	66.5	100	28	36	M6x12	116	51.7	28.5	10.4	262
OSPE50BHD	92.5	158	18	70	M6x12	164	77.0	43.0	10.4	347

Order Stroke Dimensional Requirements

Actuator Size	KM _{min}	KM _{rec}
OSPE20BHD	180	220
OSPE25BHD	210	250
OSPE32BHD	250	300
OSPE50BHD	354	400

KM_{min} is the minimum distance between two carriages possible.

KM_{rec} is the recommended distance between two carriages for optimal performance.

Order Stroke Safety Distance:

The mechanical end position should not be used as a mechanical end stop, thus an additional **Safety Distance** at both ends of travel must be incorporated into the Order Stroke. The safety distance for servo-driven systems is equivalent to the travel distance per one revolution of the drive shaft. AC motor-driven systems with VFDs require a larger safety distance than servo systems. For further information and design assistance, please consult factory.

OSPE..BHD Belt-Driven Actuators

Gearhead Mounting Kit Options

Gearhead Mounting Kits include a coupling housing and flange

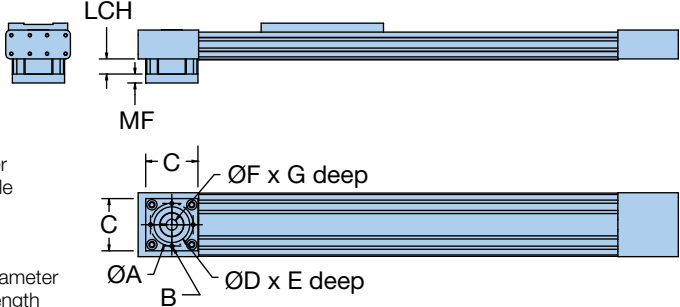

- A = Bolt circle diameter
- B = Screw for bolt circle
- C = Square dimension
- D = Pilot diameter
- E = Pilot depth
- F = Input drive shaft diameter
- G = Input drive shaft length
- LCH = Length coupling housing
- MF = Mounting flange

OSPE..BHD with Gearhead Mounting Kit

Actuator Size	Order Code Ⓒ ¹	Order Code Ⓓ ¹	Dimensions – mm								
			A	B	C	D	E	F	G	LCH	MF
OSPE20BHD	02, 03, 04 or 05	C0	44	S4	75	35	4.0	12	25	19	9.0
	0A, 0B	C1	62	S5	75	52	6.0	16	36	79	18.5
OSPE25BHD	02, 03, 04 or 05	C1	62	S5	76	52	6.0	16	36	22	13.0
OSPE32BHD	02, 03, 04 or 05	C2	80	S6	98	68	6.0	22	46	30	14.0
OSPE50BHD	02, 03, 04 or 05	C3	108	S8	130	90	6.5	32	70	41	18.0

¹ When ordering with actuator, use order code Ⓒ to specify drive shaft orientation and order code Ⓓ to specify appropriately sized gearhead mounting kit. See ordering information, page 26.

■ Blue order codes indicate rapid shipment availability



Mounted Gearhead and Motor Options

Mounted Gearhead and Motor options include a coupling housing, flange, gearhead with coupler, flange and motor

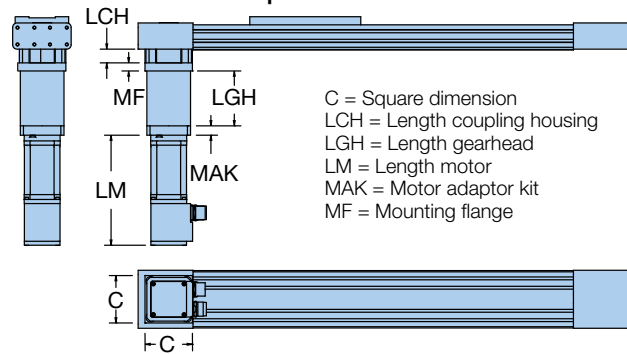

Mounted Gearhead and Mounted Motor

Actuator Size	Order Code	Order Code	Mounted Motor	Dimensions – mm					
				C	LCH	LGH	LM	MAK	MF
OSPE20BHD	Kx	KC	MPE0602A4E-KC1N	60	79	67.0	118	22.5	18.5
	Kx	K0	BE233FJ-KPSN	58	79	67.0	143	22.5	18.5
	Kx	K1	BE233FJ-KPSN with brake (CM233FJ-115027)	58	79	67.0	178	22.5	18.5
	Kx	K2	BE344LJ-KPSN	86	79	67.0	188	22.5	18.5
	Kx	K3	BE344LJ-KPSB	86	79	67.0	220	22.5	18.5
OSPE25BHD	Kx	KC	MPE0602A4E-KC1N	60	22	67.0	118	22.5	13.0
	Kx	K0	BE233FJ-KPSN	58	22	67.0	143	22.5	13.0
	Kx	K1	BE233FJ-KPSN with brake (CM233FJ-115027)	58	22	67.0	178	22.5	13.0
	Kx	K2	BE344LJ-KPSN	86	22	67.0	188	22.5	13.0
	Kx	K3	BE344LJ-KPSB	86	22	67.0	220	22.5	13.0
OSPE32BHD	Lx	KG	MPE0804A4E-KC1N	80	30	65.5	146	28.5	14.0
	Lx	K2	BE344LJ-KPSN	86	30	85.5	188	20.0	14.0
	Lx	K3	BE344LJ-KPSB	86	30	85.5	220	20.0	14.0
	Lx	M0	MPP0923D1E-KPSN	89	30	85.5	178	28.5	14.0
	Lx	M1	MPP0923D1E-KPSB	89	30	85.5	213	28.5	14.0
	Lx	M2	MPP1003D1E-KPSN	98	30	85.5	175	28.5	14.0
	Lx	M3	MPP1003D1E-KPSB	98	30	85.5	223	28.5	14.0
	Lx	M4	MPP1003R1E-KPSN	98	30	85.5	175	28.5	14.0
	Lx	M5	MPP1003R1E-KPSB	98	30	85.5	223	28.5	14.0
OSPE50BHD	Mx	KG	MPE0804A4E-KC1N	80	41	110.0	146	35.0	18.0
	Mx	K2	BE344LJ-KPSN	86	41	110.0	188	24.0	18.0
	Mx	K3	BE344LJ-KPSB	86	41	110.0	220	24.0	18.0
	Mx	M0	MPP0923D1E-KPSN	89	41	110.0	178	24.0	18.0
	Mx	M1	MPP0923D1E-KPSB	89	41	110.0	213	24.0	18.0
	Mx	M2	MPP1003D1E-KPSN	98	41	110.0	175	24.0	18.0
	Mx	M3	MPP1003D1E-KPSB	98	41	110.0	223	24.0	18.0
	Mx	M4	MPP1003R1E-KPSN	98	41	110.0	175	24.0	18.0
	Mx	M5	MPP1003R1E-KPSB	98	41	110.0	223	24.0	18.0
	Mx	M6	MPP1154B1E-KPSN	113	41	110.0	203	35.0	18.0
	Mx	M7	MPP1154B1E-KPSB	113	41	110.0	252	35.0	18.0
	Mx	M8	MPP1154P1E-KPSN	113	41	110.0	203	35.0	18.0
	Mx	M9	MPP1154P1E-KPSB	113	41	110.0	252	35.0	18.0

¹ When ordering with actuator, use order code (see page 26), to specify mounted gearhead size, ratio and orientation:

Gearhead size: **K** = PV60TA **L** = PV90TA **M** = PV115TA
 Gearhead ratio and mounting orientation: (Replace "x" to specify)

With mounting position opposite carriage: **1** = ratio 3:1 **2** = ratio 5:1 **3** = ratio 10:1
 With mounting position same side as carriage: **4** = ratio 3:1 **5** = ratio 5:1 **6** = ratio 10:1

² Use order code (see page 27), to specify choice of mounted motor.

Blue order codes indicate rapid shipment availability

OSPE..BHD Belt-Driven Actuators

Mounted Gearhead with Motor Mounting Kit Options

Mounted Gearhead with Motor Mounting Kits include a coupling housing, flange and gearhead with coupler and flange

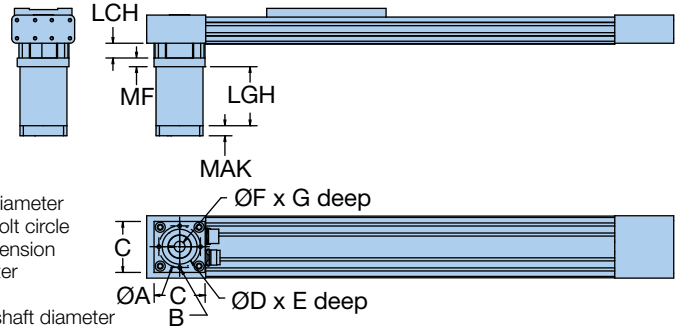

- A = Bolt circle diameter
- B = Screw for bolt circle
- C = Square dimension
- D = Pilot diameter
- E = Pilot depth
- F = Input drive shaft diameter
- G = Input drive shaft length
- LCH = Length coupling housing
- LGH = Length gearhead
- MAK = Motor adaptor
- MF = Mounting flange

Mounted Gearhead with Motor Mounting Kit

Actuator Size	Order Code ⑥ ¹	Order Code ⑦ ²	Dimensions – mm										
			A	B	C	D	E	F	G	LCH	LGH	MAK	MF
OSPE20BHD	Jx	AA	46.66	M3	43	20.00	1.6	6.35	24.8	19	48.5	19.0	9.0
	Jx	AB	66.67	M5	55	38.10	1.6	6.35	20.5	19	48.5	15.7	9.0
	Jx	B5	46.00	M4	43	30.00	2.5	6.00	25.0	19	48.5	19.0	9.0
	Jx	AM	46.00	M4	43	30.00	2.5	8.00	25.0	19	48.5	19.0	9.0
	Jx	B6	63.00	M4	55	40.00	2.5	9.00	20.0	19	48.5	13.7	9.0
	Jx	AH	63.00	M5	55	40.00	2.5	9.00	20.0	19	48.5	19.0	9.0
	Kx	AB	66.67	M5	62	38.10	1.6	6.35	20.5	79	67.0	16.5	18.5
	Kx	AC	66.67	M5	62	38.00	1.6	9.53	20.8	79	67.0	16.5	18.5
	Kx	AF	98.43	M6	85	73.00	3.0	12.70	37.0	79	67.0	30.0	18.5
	Kx	AD	66.67	M5	62	38.10	1.6	9.525	31.8	79	67.0	22.5	18.5
	Kx	AE	98.43	M5	80	73.03	3.0	12.70	30.0	79	67.0	22.5	18.5
	Kx	B6	63.00	M4	62	40.00	2.5	9.00	20.0	79	67.0	16.5	18.5
	Kx	AH	63.00	M5	62	40.00	2.5	9.00	20.0	79	67.0	16.5	18.5
	Kx	B8	70.00	M5	62	50.00	3.0	12.00	30.0	79	67.0	22.5	18.5
	Kx	AN	70.00	M5	62	50.00	3.0	14.00	30.0	79	67.0	22.5	18.5
	Kx	AG	75.00	M5	62	60.00	2.5	11.00	23.0	79	67.0	16.5	18.5
	Kx	B9	75.00	M5	62	60.00	2.5	14.00	30.0	79	67.0	22.5	18.5
	Kx	BB	90.00	M6	80	70.00	3.0	14.00	30.0	79	67.0	22.5	18.5
	Kx	A3	100.00	M6	89	80.00	3.5	14.00	30.0	79	67.0	22.5	18.5

¹ When ordering with actuator, use order code ⑥ (see page 26), to specify mounted gearhead size, ratio and orientation:

Gearhead size: **J** = PV040TA **K** = PV60TA

Gearhead ratio and mounting orientation: (Replace "x" to specify)

With mounting position opposite carriage: **1** = ratio 3:1 **2** = ratio 5:1 **3** = ratio 10:1

With mounting position same side as carriage: **4** = ratio 3:1 **5** = ratio 5:1 **6** = ratio 10:1

* 3:1 ratio not available on size OSPE20BHD (with "J" PV040TA gearhead)

² Use order code ⑦ (see page 27), to specify appropriately sized motor mounting kit. See ordering information.

■ Blue order codes indicate rapid shipment availability

(continued on next page)

(continued from previous page)

Mounted Gearhead with Motor Mounting Kit

Actuator Size	Order Code	Order Code	Dimensions – mm										
	Ⓒ ¹	Ⓓ ²	A	B	C	D	E	F	G	LCH	LGH	MAK	MF
OSPE25BHD	Kx	AB	66.67	M5	62	38.10	1.6	6.35	20.5	22	67.0	16.5	13
	Kx	AC	66.67	M5	62	38.00	1.6	9.53	20.8	22	67.0	16.5	13
	Kx	AF	98.43	M6	85	73.00	3.0	12.70	37.0	22	67.0	30.0	13
	Kx	AD	66.67	M5	62	38.10	1.6	9.525	31.8	22	67.0	22.5	13
	Kx	AE	98.43	M5	80	73.03	3.0	12.70	30.0	22	67.0	22.5	13
	Kx	B6	63.00	M4	62	40.00	2.5	9.00	20.0	22	67.0	16.5	13
	Kx	AH	63.00	M5	62	40.00	2.5	9.00	20.0	22	67.0	16.5	13
	Kx	B8	70.00	M5	62	50.00	3.0	12.00	30.0	22	67.0	22.5	13
	Kx	AN	70.00	M5	62	50.00	3.0	14.00	30.0	22	67.0	22.5	13
	Kx	AG	75.00	M5	62	60.00	2.5	11.00	23.0	22	67.0	16.5	13
	Kx	B9	75.00	M5	62	60.00	2.5	14.00	30.0	22	67.0	22.5	13
	Kx	BB	90.00	M6	80	70.00	3.0	14.00	30.0	22	67.0	22.5	13
	Kx	A3	100.00	M6	89	80.00	3.5	14.00	30.0	22	67.0	22.5	13
	OSPE32BHD	Lx	AE	98.43	M5	90	73.03	3.0	12.70	30.0	30	85.5	20.0
Lx		B6	63.00	M4	90	40.00	2.5	9.00	20.0	30	85.5	20.0	14
Lx		AH	63.00	M5	90	40.00	2.5	9.00	20.0	30	85.5	20.0	14
Lx		AN	70.00	M5	90	50.00	3.0	14.00	30.0	30	85.5	20.0	14
Lx		AG	75.00	M5	90	60.00	2.5	11.00	23.0	30	85.5	20.0	14
Lx		B9	75.00	M5	90	60.00	2.5	14.00	30.0	30	85.5	20.0	14
Lx		B0	75.00	M6	90	60.00	3.0	14.00	30.0	30	85.5	20.0	14
Lx		BB	90.00	M6	90	70.00	3.0	14.00	30.0	30	85.5	20.0	14
Lx		B4	90.00	M6	90	70.00	3.0	16.00	40.0	30	85.5	28.5	14
Lx		AP	90.00	M6	90	70.00	3.0	19.00	40.0	30	85.5	28.5	14
Lx		B3	95.00	M6	90	50.00	2.5	14.00	30.0	30	85.5	20.0	14
Lx		A3	100.00	M6	90	80.00	3.5	14.00	30.0	30	85.5	20.0	14
Lx		AL	100.00	M6	90	80.00	3.0	16.00	40.0	30	85.5	28.5	14
Lx		AJ	100.00	M6	90	80.00	3.0	19.00	40.0	30	85.5	30.0	14
Lx	A4	115.00	M8	100	95.00	3.5	19.00	40.0	30	85.5	28.5	14	
OSPE50BHD	Mx	AE	98.43	M5	115	73.03	3.0	12.70	30.0	41	110.0	24.0	18
	Mx	AG	75.00	M5	115	60.00	2.5	11.00	23.0	41	110.0	24.0	18
	Mx	B4	90.00	M6	115	70.00	3.0	16.00	40.0	41	110.0	35.0	18
	Mx	AP	90.00	M6	115	70.00	3.0	19.00	40.0	41	110.0	35.0	18
	Mx	A3	100.00	M6	115	80.00	3.5	14.00	30.0	41	110.0	24.0	18
	Mx	AL	100.00	M6	115	80.00	3.0	16.00	40.0	41	110.0	24.0	18
	Mx	AJ	100.00	M6	115	80.00	3.0	19.00	40.0	41	110.0	24.0	18
	Mx	A4	115.00	M8	115	95.00	3.5	19.00	40.0	41	110.0	24.0	18
	Mx	BD	130.00	M8	115	95.00	3.0	19.00	40.0	41	110.0	24.0	18
	Mx	AK	130.00	M8	115	110.00	3.5	24.00	50.0	41	110.0	35.0	18

¹ When ordering with actuator, use order code Ⓒ (see page 26), to specify mounted gearhead size, ratio and orientation:

Gearhead size: **L** = PV90TA **M** = PV115TA

Gearhead ratio and mounting orientation: (Replace "x" to specify)

With mounting position opposite carriage: **1** = ratio 3:1 **2** = ratio 5:1 **3** = ratio 10:1

With mounting position same side as carriage: **4** = ratio 3:1 **5** = ratio 5:1 **6** = ratio 10:1

² Use order code Ⓓ (see page 27), to specify choice of appropriately sized mounted motor. See ordering information.

■ Blue order codes indicate rapid shipment availability

OSPE..BHD Belt-Driven Actuators

End Cap Mounting Options

See "Maximum Permissible Unsupported Length" (page 24), for end cap and profile mounting requirements.

Order Code

A
(1 pair)



Type CN End Cap for OSPE20BHD, OSPE25BHD and OSPE32BHD

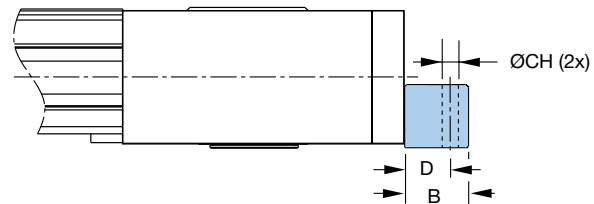
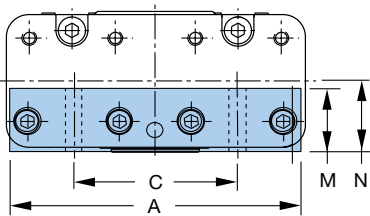

Type CN End Cap for OSPE50BHD

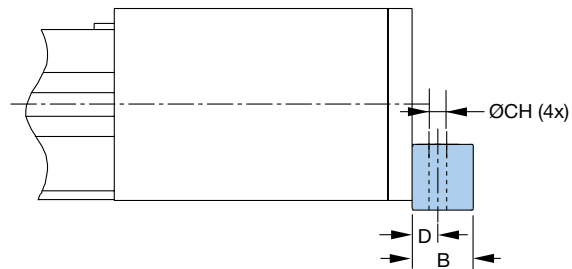
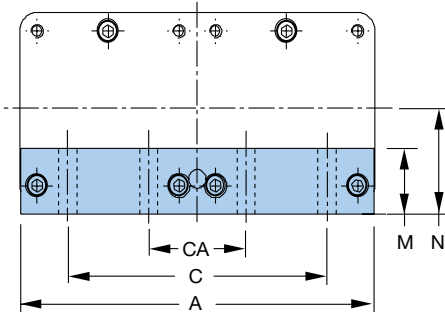

Type CN Top Mounting Block

Actuator Size	Part Number*	Weight* (kg)	Dimensions – mm							
			A	B	C	CA	ØCH	D	M	N
OSPE20BHD	16213FIL	0.165	74	20	40	—	6.6	10.0	20	22
OSPE25BHD	12266FIL	0.311	91	25	52	—	6.6	16.0	25	22
OSPE32BHD	12267FIL	0.500	114	25	64	—	9.0	18.0	25	30
OSPE50BHD	12268FIL	0.847	174	30	128	48	9.0	12.5	30	48

*When ordering with actuator, use order code . See ordering information, page 27. To order as replacement parts (per pair), use part numbers listed). Weights listed are for a single piece.

Order
Code

B
(1 pair)



Type CO End Cap for OSPE20BHD, OSPE25BHD and OSPE32BHD

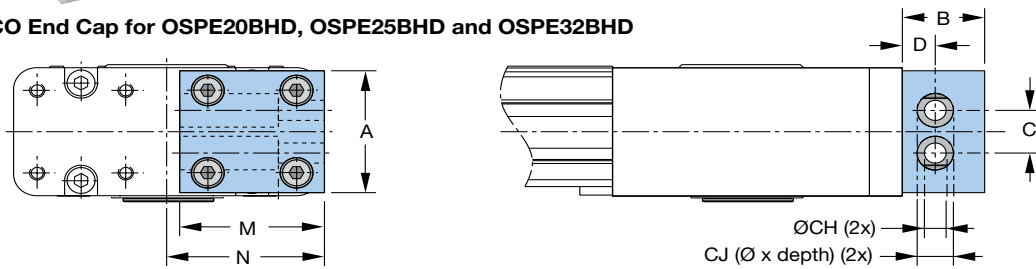

Type CO End Cap for OSPE50BHD

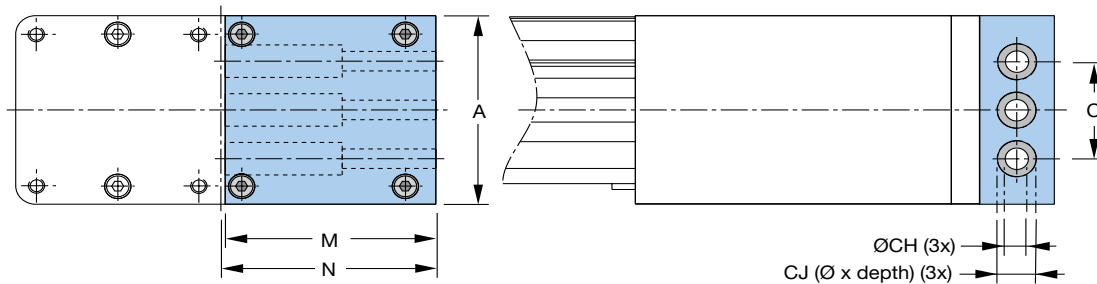

Type CO Side Mounting Block

Actuator Size	Part Number*	Weight* (kg)	Dimensions – mm							
			A	B	C	ØCH	CJ	D	M	N
OSPE20BHD	16241FIL	0.166	40	22	18	6.6	11 x 39	15.0	42	45
OSPE25BHD	16245FIL	0.221	40	25	14	6.6	11 x 30	10.0	44	48
OSPE32BHD	16246FIL	0.450	56	28	19	9.0	15 x 42	12.0	60	62
OSPE50BHD	16247FIL	1.159	87	32	45	9.0	15 x 50	16.0	90	92

*When ordering with actuator, use order code . See ordering information, page 27. To order as replacement parts (per pair), use part numbers listed. Weights listed are for a single piece.

OSPE..BHD Belt-Driven Actuators

Profile Mounting Options

See "Maximum Permissible Unsupported Length" (page 24), for end cap and profile mounting placement requirements.

Order Code

2, 5, 8 or B

(1, 2, 3 or 4 pair)

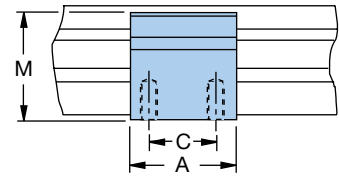
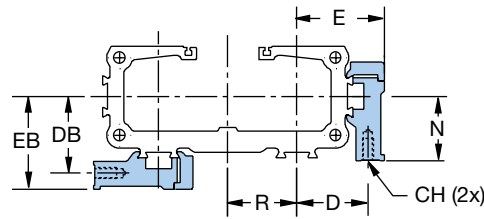

Type D1 (with internal threads)

Actuator Size	Part Number*	Weight* (kg)	Dimensions — mm									
			A	C	CH	D	DB	E	EB	M	N	R
OSPE20BHD	20008FIL	0.061	50	36	M5 x 10	20.5	28.1	28.0	35.6	38	22	23
OSPE25BHD	20008FIL	0.061	50	36	M5 x 10	27.0	28.5	34.5	36.0	38	22	26
OSPE32BHD	20157FIL	0.177	50	36	M5 x 10	33.0	35.5	40.5	43.0	46	30	32
OSPE50BHD	15534FIL	0.167	60	45	M6 x 11	40.0	45.0	52.0	57.0	71	48	44

*When ordering with actuator, use order code **D**. See ordering information, page 27. To order replacement parts (per individual unit), use part numbers listed. Part numbers and weights are for a single piece.

Order Code

1, 4, 7 or A

(1, 2, 3 or 4 pair)

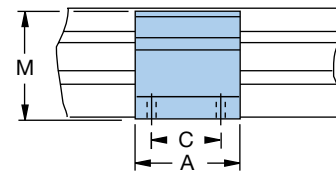
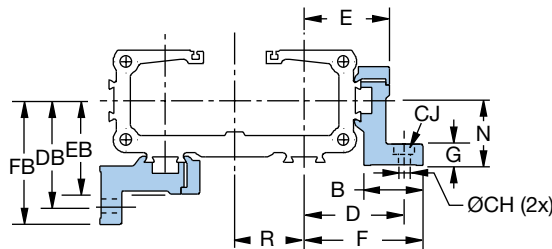

Type E1 (with 2 thru holes)

Actuator Size	Part Number*	Weight* (kg)	Dimensions — mm														
			A	B	C	ØCH	CJ	D	DB	E	EB	F	FB	G	M	N	R
OSPE20BHD	20009FIL	0.074	50	26	36	5.5	10 x 5.7	33.5	41.1	28.0	35.6	41.0	48.6	8	38	22	23
OSPE25BHD	20009FIL	0.074	50	26	36	5.5	10 x 5.7	40.0	41.5	34.5	36.0	47.5	49.0	8	38	22	26
OSPE32BHD	20158FIL	0.092	50	27	36	5.5	10 x 5.7	46.0	48.5	40.5	43.0	54.5	57.0	10	46	30	32
OSPE50BHD	15536FIL	0.189	60	34	45	7.0	—	59.0	64.0	52.0	57.0	67.0	72.0	10	71	48	44

*When ordering with actuator, use order code **D**. See ordering information, page 27. To order replacement parts (per individual unit), use part numbers listed. Part numbers and weights are for a single piece.

Order
Code

3, 6, 9 or C

(1, 2, 3 or 4 pair)

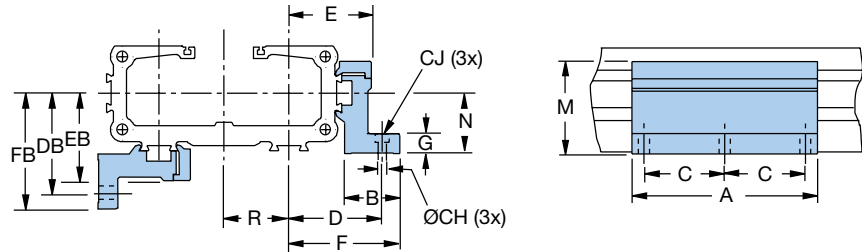

Type MAE (with 3 thru holes)

Actuator Size	Part Number*	Weight* (kg)	Dimensions – mm														
			A	B	C	ØCH	CJ	D	DB	E	EB	F	FB	G	M	N	R
OSPE20BHD	12278FIL	0.271	92	26	40	5.5	10 x 5.7	33.5	41.1	28.0	35.6	41.0	48.6	8	38	22	23
OSPE25BHD	12278FIL	0.271	92	26	40	5.5	10 x 5.7	40.0	41.5	34.5	36.0	47.5	49.0	8	38	22	26
OSPE32BHD	12279FIL	0.334	92	27	40	5.5	10 x 5.7	46.0	48.5	40.5	43.0	54.5	57.0	10	46	30	32
OSPE50BHD	12280FIL	0.668	112	34	45	7.0	—	59.0	64.0	52.0	57.0	67.0	72.0	10	71	48	44

*When ordering with actuator, use order code **Ⓢ**. See ordering information, page 27. To order replacement parts (per individual unit), use part numbers listed. Part numbers and weights are for a single piece.

OSPE..BHD Belt-Driven Actuators

Maximum Permissible Unsupported Length — Determining end cap and profile mounting placement

OSPE..BHD Series actuators need to be mounted onto a solid machine base or frame structure using appropriately positioned end cap and profile mounts. This ensures that the actuator will not undergo excessive deflection based on the application's load and length requirements.

The greater the load and/or the longer the unsupported length between mounts, the more the actuator is susceptible to deflection. Deflection is also dependent on the carriage orientation (F_z for top oriented carriage or F_y for a side mounted carriage).

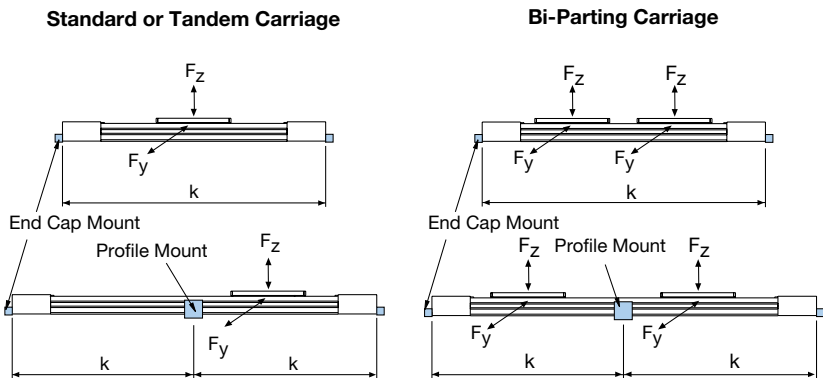

To determine correct end cap and profile mount placement, please follow the steps shown in the example below.

Use the deflection graphs on page 25 to insure that the load will not exceed the maximum allowed deflection.

Example:

A horizontal application uses an OSPE32BHD with a top oriented ball bearing carriage. The maximum load on the carriage is 30 kg and the order stroke is 2,400 mm (see page 15 to calculate order stroke).

Therefore, the overall length of the actuator will be approximately 3,000 mm:

$$2,400 \text{ mm} + 2 \times \text{Dim "X"} (262 \text{ mm}) = 2,924 \text{ mm}$$

- 1) Use the F_z graph for a top loaded ball bearing carriage (shown at right)
- 2) Calculate the Load "F" in Newtons based on the 30 kg application load requirement:

$$30 \text{ kg} \times 9.81 \text{ kg/ms}^2 = 294.3 \text{ N}$$

- 3) Draw a line from 294.3 N on the Y-axis to the OSPE32BHD curve, then down to the X-axis.
- 4) The value of "k" is approximately 750 mm.
- 5) Since the overall length (3000 mm) is greater than this value "k", the actuator will require additional fixture points— two end cap mounts and three sets of profile mounts — equally spaced to create a distance "k" of 750 mm in between.

- 6) Maximum deflection of the actuator with this mounting configuration will be less than 0.075 mm:

$$0.01\% \text{ of } 750 \text{ mm} = 0.075 \text{ mm}$$

Ball Bearing Carriage Load-Distance

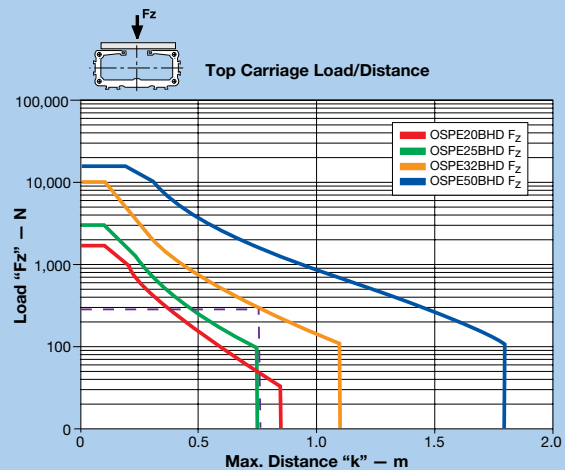

To further reduce deflection:

If the application requires less deflection, then simply reduce the distance "k" appropriately. In this example, for instance, the application must not exceed 0.05 mm. Therefore, "k" must also be 500 mm.

To achieve this reduced maximum deflection, the actuator will require seven fixture points — two end cap mounts and five pairs of profile mounts — equally spaced with a distance "k" of 500 mm in between.

Maximum Permissible Unsupported Length

Determining end cap and profile mounting placement

Use the appropriate deflection graph to ensure that the application load does not exceed the deflection curve. Supporting the actuator within the recommended maximum distance “k” will ensure that the installation will have a maximum deflection equal to 0.01% of distance “k.”

To further reduce deflection, simply reduce the distance between end cap and profile mounts as described in the example on the previous page.

Ball Bearing Carriage Load-Distance

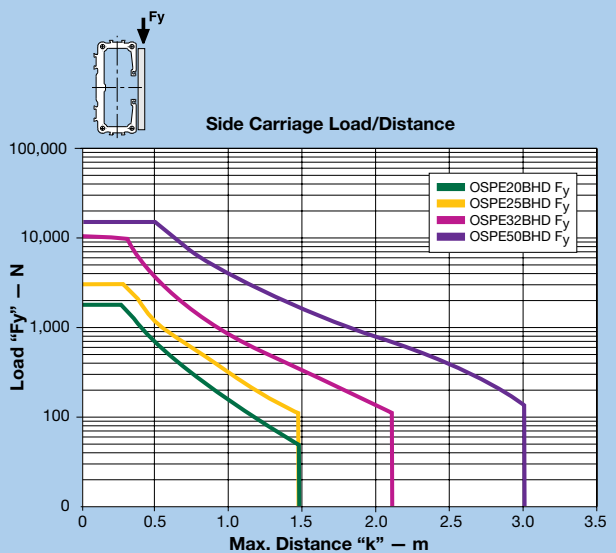
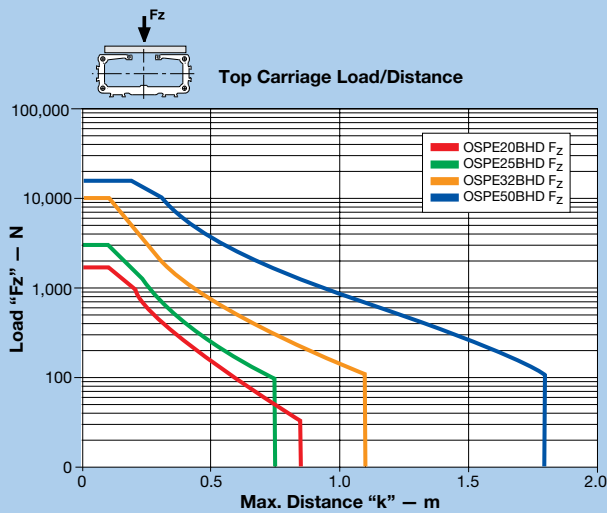

Roller Bearing Carriage Load-Distance

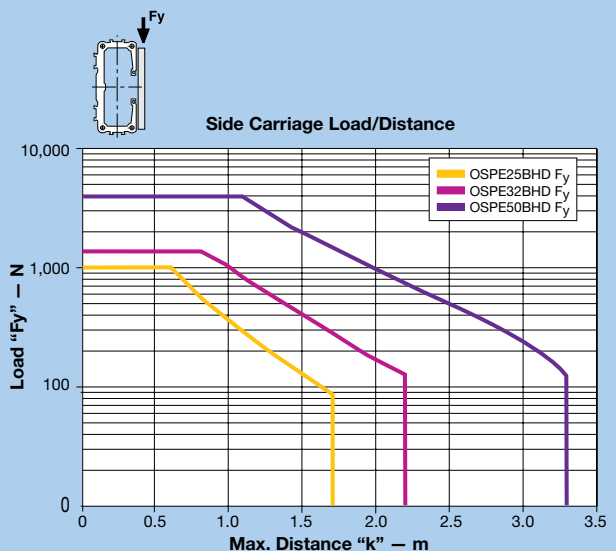
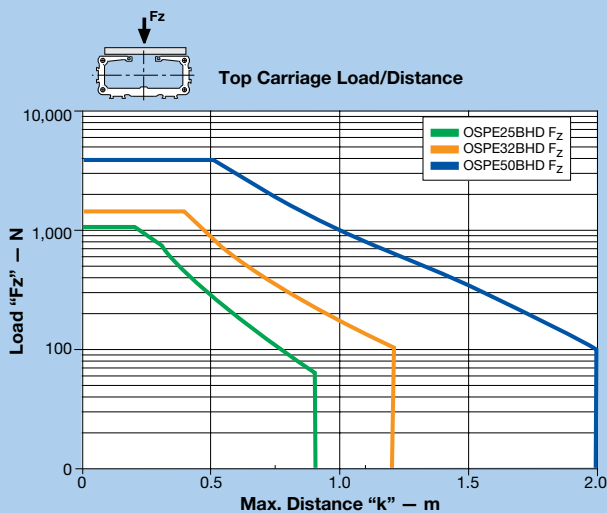

OSPE..BHD Belt-Driven Actuators

Ordering Information

Select an order code from each of the numbered fields to create a complete OSPE..BHD model order number. Include hyphens and non-selective characters as shown in example below.

① ② ③ ④ ⑤ ⑥ ⑦ ⑧ ⑨ ⑩ ⑪ ⑫

Order Number Example: OSPE 25 - 6 0 0 02 - 00000 - P 00 0 0 0

① Series

OSPE Origa System Plus Electromechanical

② Actuator Bore Size

20 73 mm W x 49 mm H

25 93 mm W x 53 mm H

32 116 mm W x 67 mm H

50 175 mm W x 93 mm H

③ Drive Train

5 Belt actuator with integrated roller guide
(Available upon request — consult factory)

6 Belt actuator with integrated ball bearing guide

④ Carriage

0 Standard

1 Tandem (two carriages for higher load capabilities)

2 Bi-Parting (two driven carriages with opposing movements)

⑤ Operating Direction and Magnet Position*

(See blue inset box (page 27) for parallel actuators operating direction)

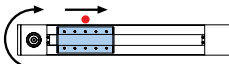
0  Standard (Carriage moves away from drive end)

1  Standard (Carriage moves toward drive end)

0  Tandem (Carriage moves away from drive end)

1  Tandem (Carriage moves toward drive end)

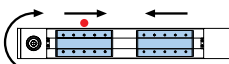
2  Bi-Parting (Carriages move toward mid-actuator)

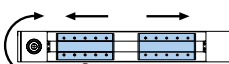
3  Bi-Parting (Carriages move away from mid-actuator)

* Sensors must be mounted in the side or bottom dovetail groove on the same side of the actuator with mounted magnet (•)

⑥ Drive Shaft and Gearhead/Motor Options Configuration and Orientation

02  Clamp shaft¹ (opposite carriage side)
Clamp

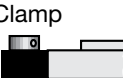
04  Clamp shaft¹ (same side as carriage)
Clamp

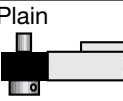
03  Plain shaft² (opposite carriage side) with plain shaft to connect this master actuator in parallel with idler actuator using a link shaft
Clamp

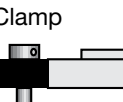
05  Plain shaft² (same side as carriage) with plain shaft to connect this master actuator in parallel with idler actuator using a link shaft
Clamp

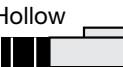
06  Hollow shaft with keyway (opposite carriage side)
Hollow

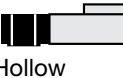
07  Hollow shaft with keyway (same side as carriage)
Hollow

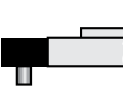
0A  Plain shaft² (opposite carriage side) to connect this idler actuator in parallel with a master actuator using a link shaft
Plain

0B  Plain shaft² (same side as carriage) to connect this idler actuator in parallel with a master actuator using a link shaft
Plain

Jx PV040TA
Kx PV060TA
Lx PV090TA
Mx PV115TA
Mounted Gearhead Options³
(replace “x” with appropriate ratio and orientation)

¹ See page 16 for available Gearhead Mounting Kit Options.

² Only available with order code 00 “No gearhead mounting kit or motor option” (item ⑤)

³ Requires motor or motor mounting kit selection for item ⑤ below. See “Mounted Gearhead and Motor” page 17 or “Mounted Gearhead with Motor Mounting Kit” page 18 for details and dimensions

■ Blue order codes indicate rapid shipment availability

⑦ Order Stroke* (see page 15)

00000 5-digit input (in mm)

* Maximum standard stroke:

OSPE20BHD = 05760 mm

OSPE25HD = 05700 mm

OSPE32BHD = 05600 mm

OSPE50BHD = 05500 mm

Longer strokes available upon request. Consult factory.

⑧ Hardware and Cover Strip

P Standard hardware with Parker gold cover strip

⑨ Gearhead/Motor Mounting Options

00 No gearhead or motor mounting option

Gearhead Mounting Kits (see page 16 for available option dimensions and delivery)

Mounted Gearhead and Motor (see page 17 for available option dimensions and delivery)

Mounted Gearhead with Motor Mounting Kit (see page 18 for available option dimensions and delivery)

⑩ End Cap Mounting (see page 20)

0 No end cap mounting

A 1 pair CN (for top carriage mounting)

B 1 pair CO (for side carriage mounting)

⑪ Profile Mounting (see page 22)

0 No profile mounting

2 1 pair D1 (with 2 internal threads)

5 2 pair D1 (with 2 internal threads)

8 3 pair D1 (with 2 internal threads)

B 4 pair D1 (with 2 internal threads)

1 1 pair E1 (with 2 thru holes)

4 2 pair E1 (with 2 thru holes)

7 3 pair E1 (with 2 thru holes)

A 4 pair E1 (with 2 thru holes)

3 1 pair MAE (with 3 thru holes)

6 2 pair MAE (with 3 thru holes)

9 3 pair MAE (with 3 thru holes)

C 4 pair MAE (with 3 thru holes)

⑫ Magnetic Sensor Mounting*

0 No sensor mounting

A 1 pc. N.O., NPN, with M8 connector

B 2 pc. N.C., NPN, with M8 connector

C 1 pc. N.O., NPN, with M8 connector
2 pc. N.C., NPN, with M8 connector

D 1 pc. N.O., PNP, with M8 connector

E 2 pc. N.C., PNP, with M8 connector

F 1 pc. N.O., PNP, with M8 connector
2 pc. N.C., PNP, with M8 connector

* Extension cable with M8 plug and 5 m cable flying lead cable for Sensor with M8 connector can be ordered separately; use part number 003-2918-01

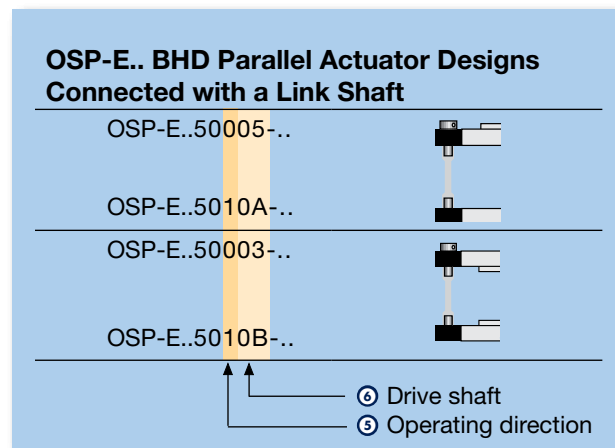

■ Blue order codes indicate rapid shipment availability

OSPE..B Belt-Driven Actuators

Actuators for Point-to-Point Applications

The field-proven OSPE..B design is the industry standard for the widest array of point-to-point linear traverse applications. Compact size and maximum configurability make the OSPE..B easy to integrate into any machine layout simply and neatly.

To meet rigorous environmental and maximum performance criteria, the OSPE..B Series is optionally available with the PowerSlide and ProLine external bearing which can be installed in any position (top, side or bottom of the actuator) and retrofitted to existing actuators.

Advantages:

- Precise path and position control
- High-speed operation
- Easy installation
- Low maintenance
- Ideal for precise point-to-point applications

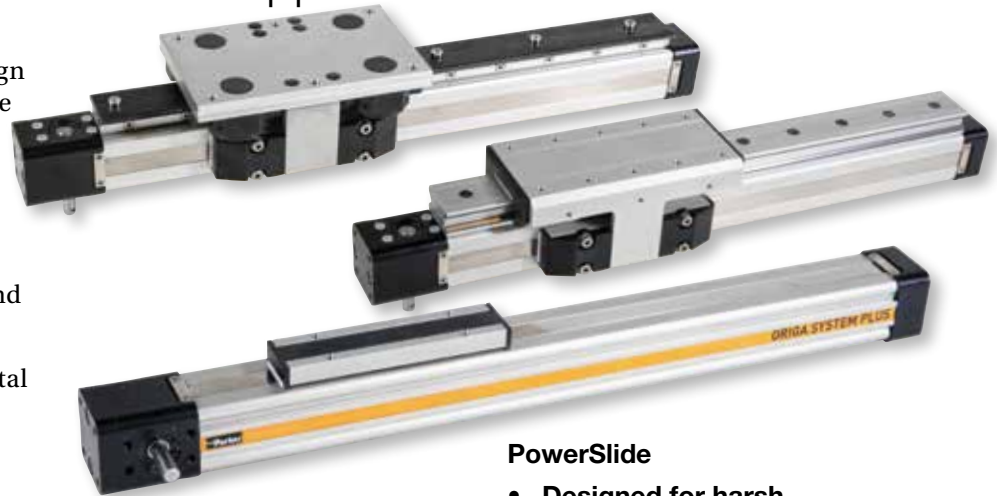

Features:

- Integrated drive and guidance system
- Tandem carriage with second carriage for increased load capabilities
- Long available strokes
- Complete motor, gearhead and control packages
- Diverse range of accessories and mountings
- Bi-parting carriages and special options available
- Ambient temperature range -30°C to +80°C
- IP 54 rated

PowerSlide

- Designed for harsh environments
- Speed up to 3 m/s
- Hardened steel guide rail
- Carriage with steel v-wheels
- Tough roller cover with wiper and grease access point

ProLine

- Designed for high-speed, precise, smooth and quiet operation
- Aluminum rail with ground and calibrated steel trucks
- Carriage supported by needle bearing rolls
- Integrated wipers to keep bearing system clean
- Lifetime lubricated bearing system

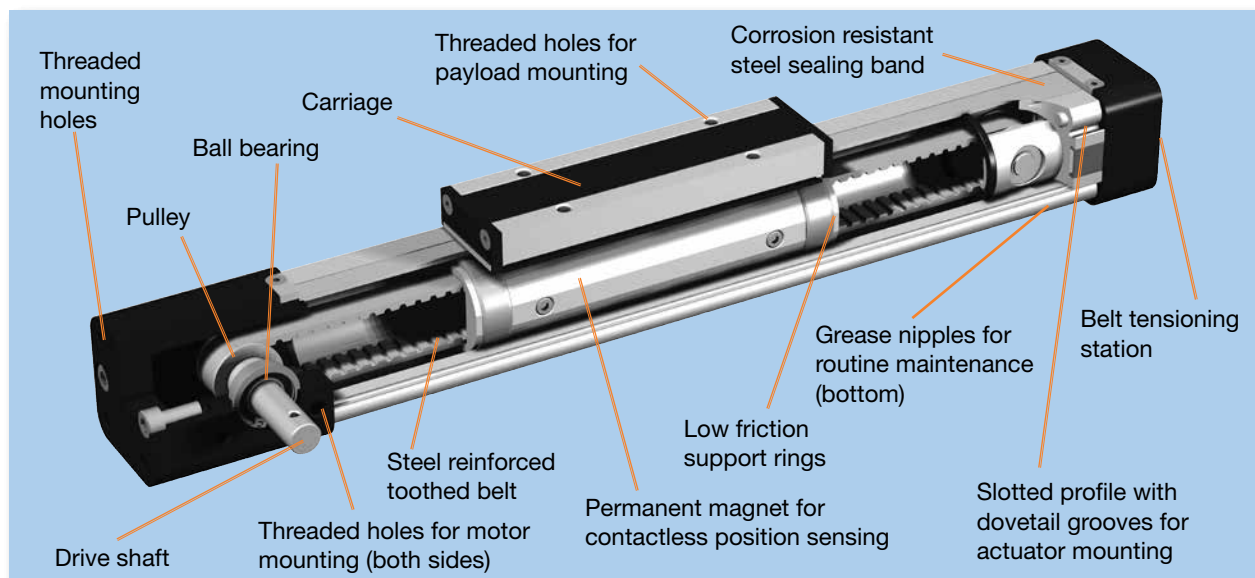

Choose from a Wide Range of Standard Options for Maximum Design Flexibility in a Pre-assembled Solution

Carriage Bearing Design Configurations



Standard carriage — with internal glider bearing



PowerSlide — externally mounted steel roller guide for higher load capabilities specifically in harsh environments



ProLine — externally mounted aluminum roller guide for higher load capabilities in high speed applications

Optional Carriage Orientation (for standard carriage only)



Tandem carriage — for higher load capabilities



Bi-parting carriage — for opposing synchronized movements



Clevis mounting — provides compensation between actuator and guide rails in machine designs

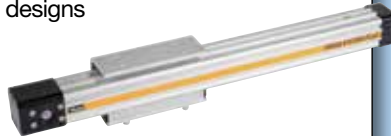

Inversion mounting — allows outer band to be on the bottom, while keeping payload on top, for better actuator protection in dirty environments

Actuator Mounting Options



End cap mounting — allows the actuator to be anchored by the end caps



Profile mounting — supports long travel actuators or for direct mounting

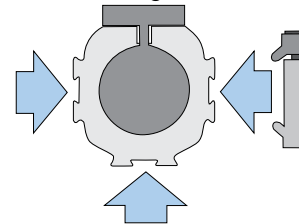

Drive Shaft Options

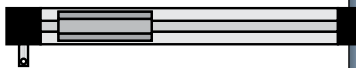

Plain drive shaft left



Plain drive shaft right

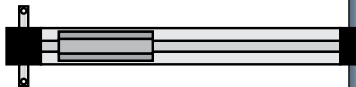

Double plain drive shaft — to connect master unit with idler unit

Multi-axis Systems

A wide range of adapter plates and intermediate drive shafts simplifies engineering and installation.

Please consult factory for your individual system design.

Options and Accessories



Information on all OSPE..B Series options are detailed on the following pages. Simply select all the options needed to solve your application requirements, then order with the actuator using convenient order codes (see last pages of the OSPE..B section). To order an option separately as an upgrade to an existing system or as a replacement part, use the individual option part numbers provided.

OSPE..B Belt-Driven Actuators

General Specifications

Actuator Size			OSPE25B	OSPE32B	OSPE50B
Travel Distance per Rev	S_{lin}	mm	60	60	100
Pulley Diameter		mm	19.10	19.10	31.83
Linear Speed (Max)	v_{max}	m/s	2	3	5 ¹
Acceleration (Max)	a_{max}	m/s ²	10	10	10
Repeatability (unidirectional)		μm	± 50	± 50	± 50
Thrust Force (Max)	F_{Amax}	N	50	150	425
		lbs	11	34	96
Torque on Drive Shaft (Max)	M_{Amax}	Nm	0.9	1.9	7.4
		in-lb	8	17	65
Inertia					
@ Zero Stroke	J_0	kgmm ²	25	43	312
		kgmm ² /m	6.6	10.0	45.0
Per Meter of Stroke					
Per 1 kg Moved Mass		J_m	91	91	253
Ambient Temperature Range		°C		-30 to +80	
IP Rating)				IP 54	

¹ Maximum linear speed for OSPE50B with PowerSlide bearing is 3 m/s

Available Thrust Force

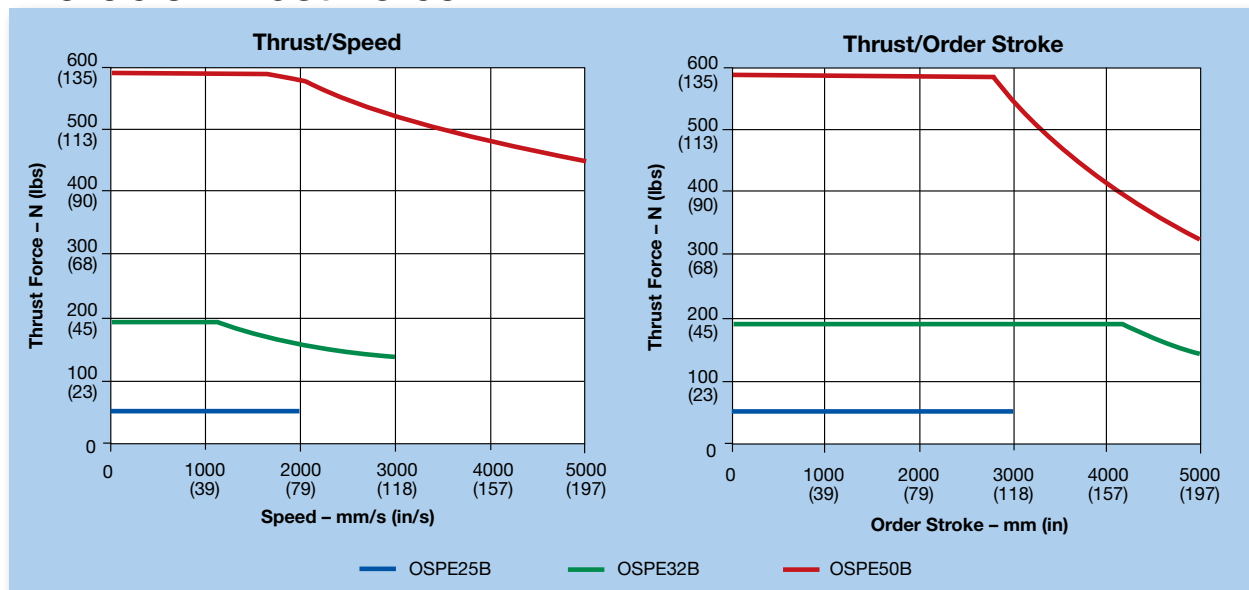

Calculating Load Factors - Combined Normal and Moment Load

The sum of combined loads (static and dynamic) must not exceed "1" at any time as shown in the formula below:

$$\frac{F_z}{F_z(\max)} + \frac{M_x}{M_x(\max)} + \frac{M_y}{M_y(\max)} + \frac{M_z}{M_z(\max)} \leq 1$$

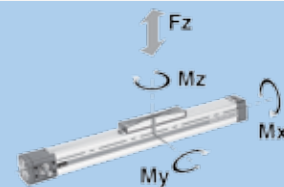

$$M = F \times l \text{ (Nm)}$$

$$M_x = M_{x \text{ static}} + M_{x \text{ dynamic}}$$

$$M_y = M_{y \text{ static}} + M_{y \text{ dynamic}}$$

$$M_z = M_{z \text{ static}} + M_{z \text{ dynamic}}$$

OSPE25B Performance

Carriage (Bearing System)			Standard Carriage	PowerSlide			ProLine PL25
				PS25/25	PS25/35	PS25/44	
Part Number ¹			—	20304	20305	20306	20874
Max Order Stroke ²	OS _{max}	mm	3000	3000	3000	3000	3000
Normal Load ³ (Max)	F _Y / F _Z	N (lbs)	160 (36)	197 (44)	219 (49)	387 (87)	1549 (348)
Moment Load ³ (Max)	M _X	Nm (in-lb)	2 (18)	3 (27)	4 (35)	6 (53)	30 (266)
	M _Y	Nm (in-lb)	12 (106)	14 (124)	15 (133)	57 (504)	69 (611)
	M _Z	Nm (in-lb)	8 (71)	14 (124)	15 (133)	57 (504)	69 (611)
Torque — No Load ⁴	M ₀	Nm (in-lb)	0.4 (4)	0.6 (5)	0.6 (5)	0.6 (5)	0.6 (5)
@ 0 Stroke	m ₀	kg (lbs)	0.7 (1.54)	1.0 (2.20)	1.1 (2.42)	1.3 (2.86)	0.9 (1.98)
Weight Per Meter of Stroke	m _{OS}	kg (lbs)	1.6 (3.52)	3.0 (6.60)	3.4 (7.48)	4.2 (9.24)	3.3 (7.26)
Carriage ⁴	m _C	kg (lbs)	0.2 (0.44)	0.9 (1.98)	1.0 (2.20)	1.7 (3.74)	1.0 (2.20)

OSPE32B Performance

Carriage (Bearing System)			Standard Carriage	PowerSlide		ProLine PL32
				PS32/35	PS32/44	
Part Number ¹			—	20307	20308	20875
Max Order Stroke ²	OS _{max}	mm	5000	3500	3500	3750
Normal Load ³ (Max)	F _Y / F _Z	N (lbs)	300 (67)	303 (68)	747 (168)	2117 (476)
Moment Load ³ (Max)	M _X	Nm (in-lb)	8 (71)	4 (35)	16 (142)	52 (460)
	M _Y	Nm (in-lb)	25 (221)	15 (133)	57 (504)	132 (1168)
	M _Z	Nm (in-lb)	16 (142)	15 (133)	57 (504)	132 (1168)
Torque — No Load ⁴	M ₀	Nm (in-lb)	0.5 (4)	0.8 (7)	0.8 (7)	0.8 (7)
@ 0 Stroke	m ₀	kg (lbs)	1.5 (2.64)	1.9 (4.18)	2.1 (4.62)	2.0 (4.40)
Weight Per Meter of Stroke	m _{OS}	kg (lbs)	3.2 (7.04)	5.1 (11.22)	5.9 (12.98)	5.8 (12.76)
Carriage ⁴	m _C	kg (lbs)	0.4 (0.88)	1.2 (2.64)	1.9 (4.18)	1.6 (3.52)

OSPE50B Performance

Carriage (Bearing System)			Standard Carriage	PowerSlide		ProLine PL50
				PS50/60	PS50/76	
Part Number ¹			—	20309	20310	20876
Max Order Stroke ²	OS _{max}	mm	5000	3500	3500	3750
Normal Load ³ (Max)	F _Y / F _Z	N (lbs)	850 (191)	975 (219)	1699 (382)	5626 (1265)
Moment Load ³ (Max)	M _X	Nm (in-lb)	16 (142)	29 (257)	59 (522)	201 (1779)
	M _Y	Nm (in-lb)	80 (708)	81 (717)	149 (1319)	451 (3992)
	M _Z	Nm (in-lb)	32 (283)	81 (717)	149 (1319)	451 (3992)
Torque — No Load ⁴	M ₀	Nm (in-lb)	0.6 (5)	0.9 (8)	0.9 (8)	0.9 (8)
@ 0 Stroke	m ₀	kg (lbs)	4.2 (9.24)	5.5 (12.10)	6.3 (13.86)	5.4 (11.88)
Weight Per Meter of Stroke	m _{OS}	kg (lbs)	6.2 (13.64)	10.4 (22.88)	12.8 (28.16)	10.0 (22.00)
Carriage ⁴	m _C	kg (lbs)	1.0 (2.20)	3.3 (7.26)	5.9 (12.98)	3.5 (7.70)

¹ PowerSlide or ProLine guide bearings can be ordered individually with assigned part number in the table and specified, five digit order stroke value (mm), following the part number (-nnnn) to designate the appropriate length guide rail. To order PowerSlide or Proline bearing with the actuator, use the appropriate order in item ④ on page 49.

² Longer strokes available upon request. Contact factory.

³ Load and moment based on 8000 km performance Refer to "Calculating Load Factors" on facing page for additional information.

⁴ For tandem and bi-parting options, double the values listed.

OSPE..B Belt-Driven Actuators

Base Unit Dimensions w/Standard Carriage — mm



Standard Carriage

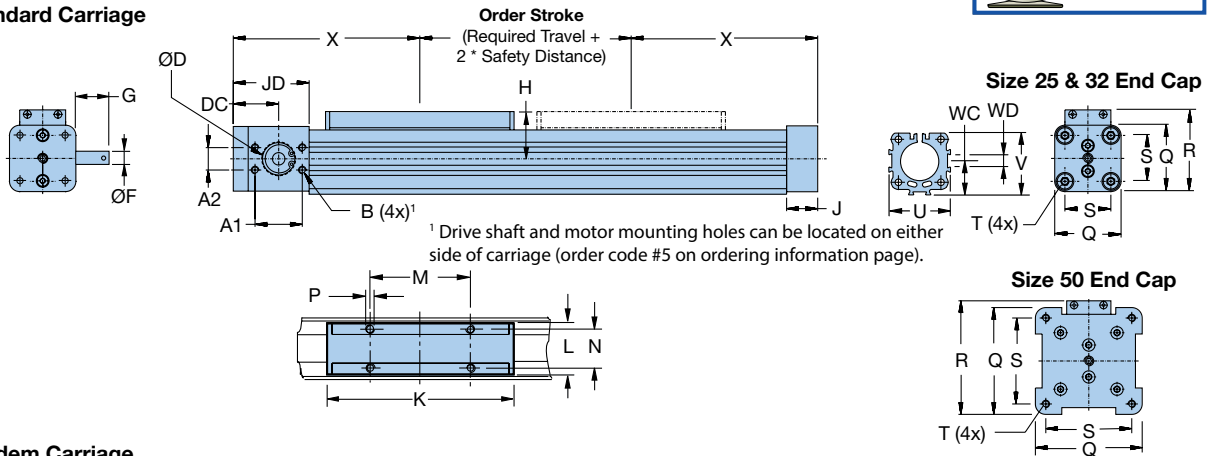

Tandem Carriage

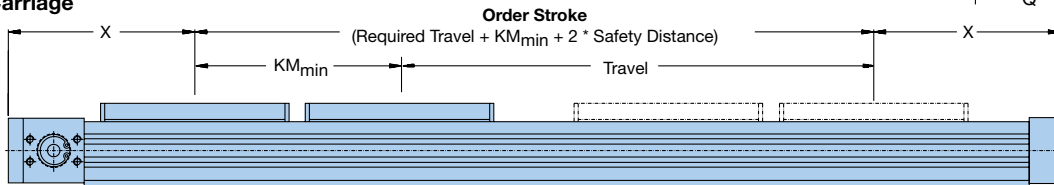

Bi-Parting Carriage

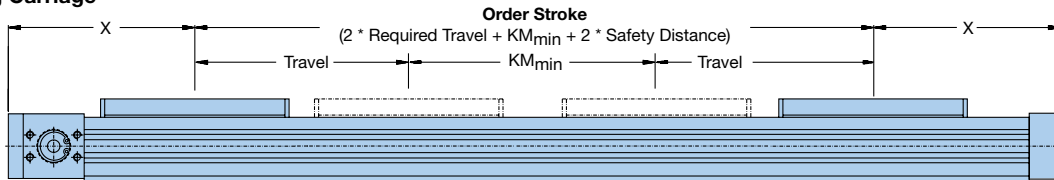

* See page 34 for clevis mount or page 35 for inversion mount optional carriage dimensions.

Actuator Size	A	A1	A2	B	D	DC	F	G	H	J	JD	K
OSPE25B	33.5	30	15	M5 x 10	19 ^{H7}	37.0	10 _{j6}	24	31	22	57	117
OSPE32B	42.0	38	18	M6 x 12	26 ^{H7}	36.5	10 _{j6}	26	38	25	61	152
OSPE50B	59.4	50	32	M8 x 16	40 ^{H7}	48.5	16 _{h8}	34	49	25	85	200

	L	H	N	P	Q	R	S	T	U	V	WC	WD	X
OSPE25B	33	65	25	M5 x 8	41	52.5	27	M5 x 10	40	39.5	21.5	10.4	125
OSPE32B	36	90	27	M6 x 10	52	66.5	36	M6 x 12	52	51.7	28.5	10.4	150
OSPE50B	36	110	27	M6 x 10	87	92.5	70	M6 x 12	76	77	43.0	10.4	200

Order Stroke Dimensional Requirements

Actuator Size	KM _{min}	KM _{rec}
OSPE25B	130	190
OSPE32B	170	230
OSPE50B	220	320

KM_{min} is the minimum distance between two carriages possible; KM_{rec} is the recommended distance for optimal performance.

Order Stroke Safety Distance:

The mechanical end position should not be used as a mechanical end stop, thus an additional **Safety Distance** at both ends of travel must be incorporated into the Order Stroke. The safety distance for servo-driven systems is equivalent to the travel distance per revolution of the drive shaft. AC motor-driven systems with VFD require a larger safety distance than servo systems. For further information and design assistance, please consult factory.

PowerSlide Dimensions — mm

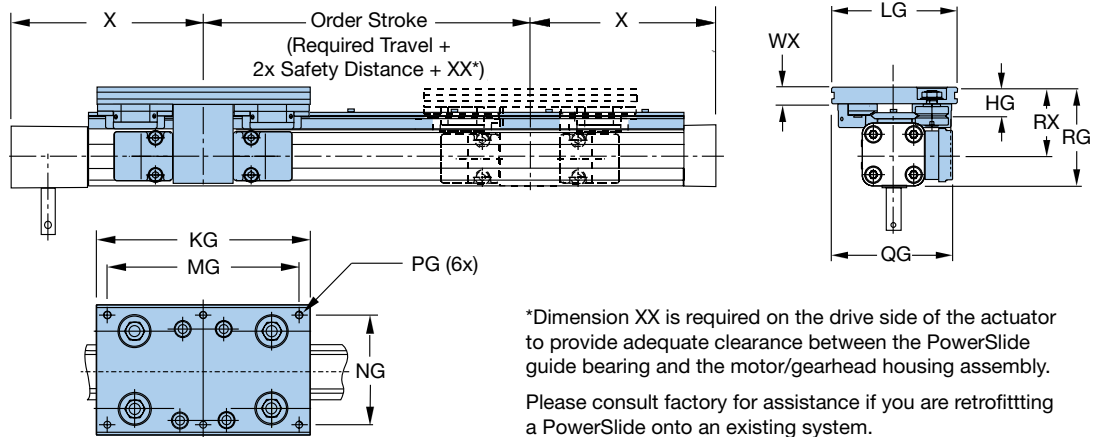

*Dimension XX is required on the drive side of the actuator to provide adequate clearance between the PowerSlide guide bearing and the motor/gearhead housing assembly. Please consult factory for assistance if you are retrofitting a PowerSlide onto an existing system.

Guide Rail Size	HG	KG	LG	MG	NG	PG	QG	RG	RX	WX	X	XX
PS25/25	20.0	145	80	125	64	M6 x 11	79.5	73.5	53.0	11.0	125	5
PS25/35	21.5	156	95	140	80	M6 x 12	89.5	73.0	52.5	12.5	125	10
PS25/44	26.0	190	116	164	96	M8 x 15	100.0	78.5	58.0	15.0	125	27
PS32/35	21.5	156	95	140	80	M6 x 12	95.5	84.5	58.5	12.5	150	—
PS32/44	26.0	190	116	164	96	M8 x 15	107.0	90.0	64.0	15.0	150	6
PS50/60	28.5	240	135	216	115	M8 x 17	130.5	123.5	81.0	17.0	200	5
PS50/76	39.0	280	185	250	160	M10 x 20	155.5	135.5	93.0	20.0	200	25

ProLine Dimensions — mm

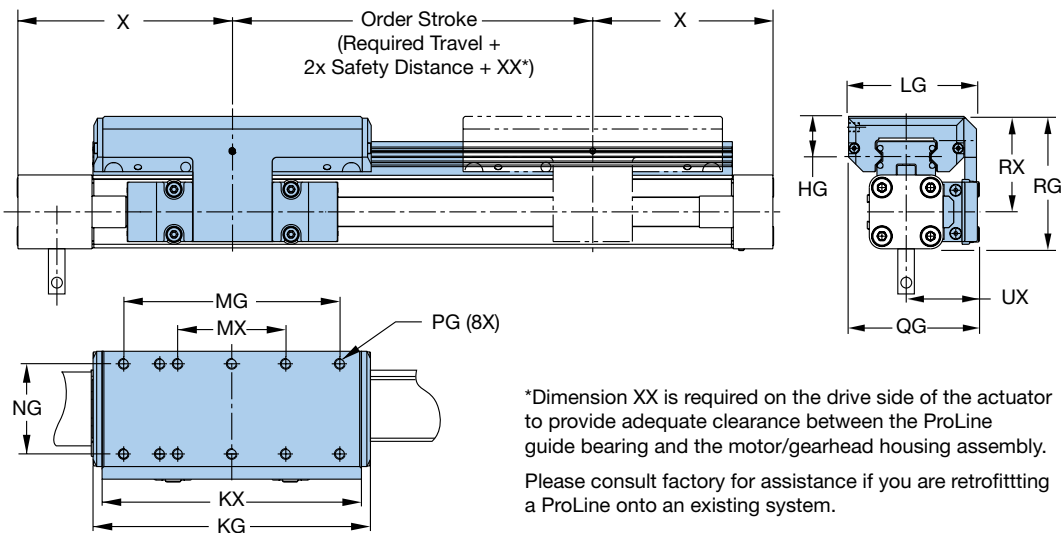

*Dimension XX is required on the drive side of the actuator to provide adequate clearance between the ProLine guide bearing and the motor/gearhead housing assembly. Please consult factory for assistance if you are retrofitting a ProLine onto an existing system.

Guide Rail Size	HG	KG	KX	LG	MG	MX	NG	PG	QG	RG	RX	UX	X	XX
PL25	23	154	144	64	120	60	50	M6 x 12	72.5	74	53	40.5	125	10
PL32	25	197	187	84	160	80	64	M6 x 12	91.0	88	62	49.0	150	11
PL50	29	276	266	110	240	120	90	M6 x 16	117.0	118	75	62.0	200	24

OSPE..B Belt-Driven Actuators

Order Code

R Clevis Mounting Option for Standard Carriage

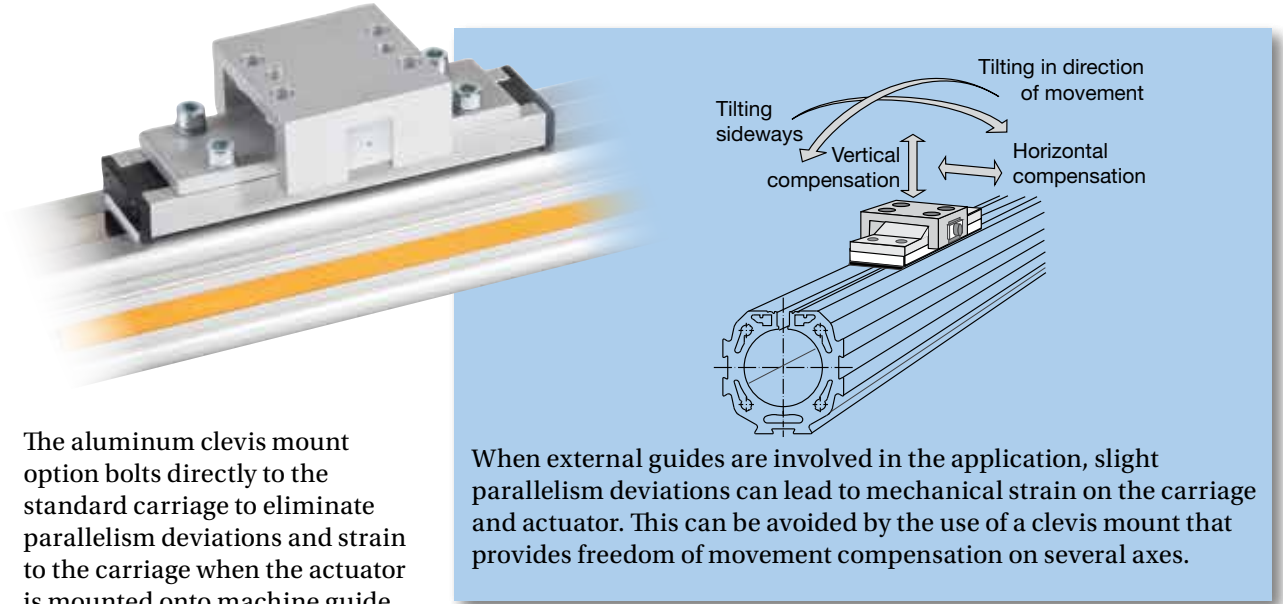

The aluminum clevis mount option bolts directly to the standard carriage to eliminate parallelism deviations and strain to the carriage when the actuator is mounted onto machine guide rails. Clevis mounting provides compensation for misalignment in Z and Y directions and can tilt around the X and Y axis.

When external guides are involved in the application, slight parallelism deviations can lead to mechanical strain on the carriage and actuator. This can be avoided by the use of a clevis mount that provides freedom of movement compensation on several axes.

OSPE25 and OSPE32

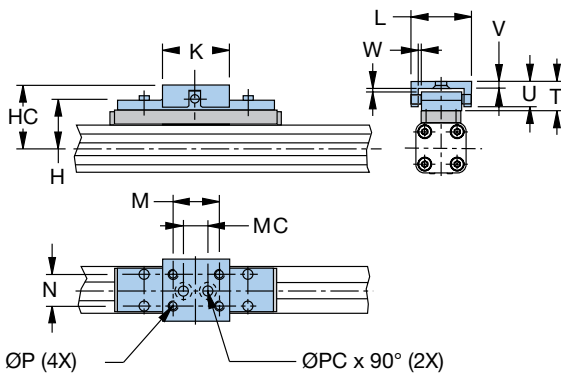

OSPE50

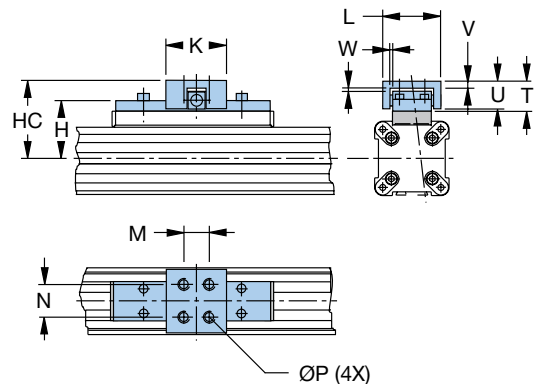

Actuator Size	Part Number*	Weight* (kg)	Dimensions – mm												
			H	HC	K	L	M	MC	N	P	PC	T	U	V	W
OSPE25B	20005FIL	0.091	39	52	40	38	30	16	16	M5	5.5	21	19	3.5	2
OSPE32B	20096FIL	0.091	50	68	60	62	46	40	25	M6	6.6	30	28	6.0	2
OSPE50B	20097FIL	0.308	61	79	60	62	46	—	25	M6	—	30	28	6.0	2

*Part number and weight are for individual unit.

M Inversion Mounting Option for Standard Carriage



For dirty environments or space-restricted installations, inversion of the actuator is recommended.

The aluminum inversion bracket transfers the driving force to the opposite side of the actuator

allowing the load to be attached to the top side of the actuator while the carriage and sealing band remain protected on the bottom side. The size and position of the mounting holes are the same as on the standard carriage.

Note: Profile mounts and magnetic switches can only be used on the free side of the actuator.

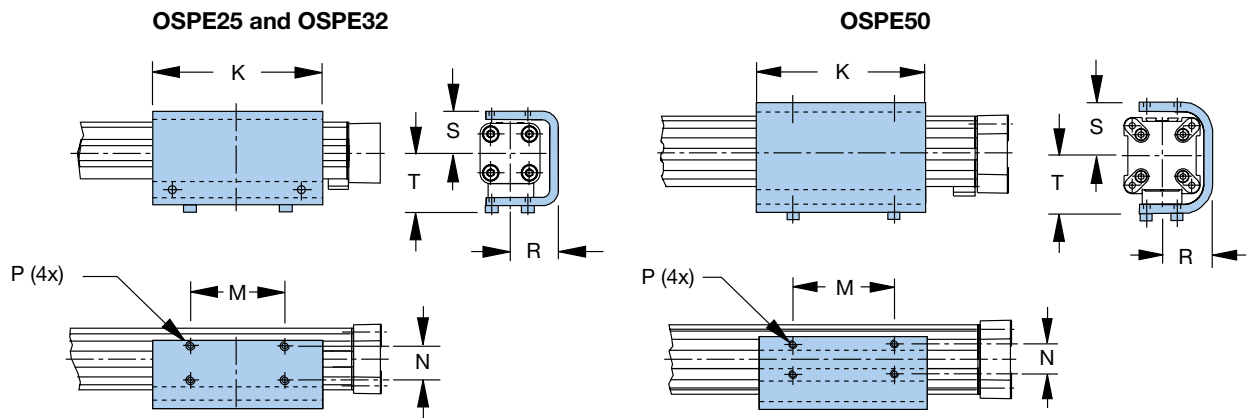

Actuator Size	Part Number*	Weight* (kg)	Dimensions – mm						
			K	M	N	P	R	S	T
OSPE25B	20037FIL	0.302	117	65	25	M5 x 6	33.5	31	31
OSPE32B	20161FIL	0.449	150	90	27	M6 x 6	39.5	38	38
OSPE50B	20166FIL	0.947	200	110	27	M6 x 8	52.0	55	55

*Part number and weight are for individual unit.

OSPE..B Belt-Driven Actuators

Motor Mounting Kit Options

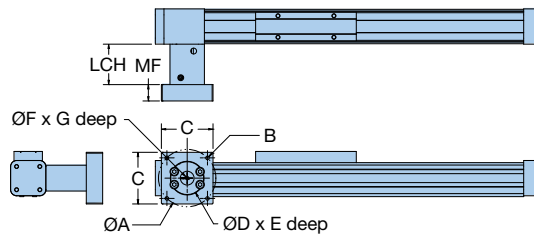

A = Bolt circle diameter
 B = Screw for bolt circle
 C = Square dimension
 D = Pilot diameter
 E = Pilot depth
 F = Input drive shaft diameter
 G = Input drive shaft length
 LCH = Length coupling housing
 MF = Motor flange

Motor Mounting Kits include a coupling housing, coupling and flange

Note: Screw thread to mount motor to flange plate is M3

Actuator Size	Order Code ⑥ *	Order Code ⑦ *	Dimensions — mm								
			A	B	C	D	E	F	G	LCH	MF
OSPE25B	0	AA	46.66	M3	41	20.00	1.6	6.35	24.8	47	12
	0	AB	66.67	M5	60	38.10	1.6	6.35	20.5	47	9
	0	AC	66.67	M5	60	38.10	1.6	9.53	20.8	47	9
	0	AD	66.67	M5	60	38.10	1.6	9.525	31.8	47	19
	0	B5	46.00	M4	60	30.00	2.5	6.00	25.0	47	12
	0	AM	46.00	M4 ¹	41	30.00	2.5	8.00	25.0	47	12
	0	B6	63.00	M4	60	40.00	2.5	9.00	20.0	47	10
	0	AH	63.00	M5	60	40.00	2.5	9.00	20.0	47	12
	0	A2	63.00	M5	60	40.00	2.5	11.00	23.0	47	12
	0	B7	70.00	M5	60	50.00	3.0	8.00	25.0	47	17
	0	B8	70.00	M5	60	50.00	3.0	12.00	30.0	47	17
	0	AG	75.00	M5	70	60.00	2.5	11.00	23.0	47	10
	0	B1	90.00	M5	75	60.00	2.5	11.00	23.0	47	10
OSPE32B	0	AB	66.67	M5	60	38.10	1.6	6.35	20.5	49	10
	0	AC	66.67	M5	60	38.10	1.6	9.525	20.8	49	10
	0	AF	98.43	M6	85	73.03	3.0	12.70	37.0	49	26
	0	AD	66.67	M5	60	38.10	1.6	9.525	31.8	49	18
	0	AE	98.43	M5	85	73.03	3.0	12.70	30.0	49	16
	0	B6	63.00	M4	55	40.00	2.5	9.00	20.0	49	11
	0	AH	63.00	M5	60	40.00	2.5	9.00	20.0	49	11
	0	A2	63.00	M5	60	40.00	2.5	11.00	23.0	49	11
	0	BJ	66.67	M5	60	38.10	1.6	12.70	20.0	49	10
	0	B7	70.00	M5	60	50.00	3.0	8.00	25.0	49	16
	0	B8	70.00	M5	60	50.00	3.0	12.00	30.0	49	16
	0	AN	70.00	M5	60	50.00	3.0	14.00	30.0	49	16
	0	AG	75.00	M5	70	60.00	2.5	11.00	23.0	49	11
	0	B9	75.00	M5	70	60.00	2.5	14.00	30.0	49	16
	0	BA	75.00	M5	70	60.00	3.0	16.00	40.0	49	26
	0	B0	75.00	M6	70	60.00	3.0	14.00	30.0	49	16
	0	B1	90.00	M5	75	60.00	2.5	11.00	23.0	49	11
	0	B2	90.00	M5	75	60.00	2.5	14.00	30.0	49	16
	0	BB	90.00	M6	80	70.00	3.0	14.00	30.0	49	16
	0	B4	90.00	M6	80	70.00	3.0	16.00	40.0	49	26
0	B3	95.00	M6	80	50.00	2.5	14.00	30.0	49	16	

*When ordering with actuator, use order code ⑥ (gearhead designation) and order code ⑦ to specify motor mounting kit. See ordering information, page 48.

■ Blue order codes indicate rapid shipment availability

(continued on next page)

(continued from previous page)

Actuator Size	Order Code ⑥ *	Order Code ⑦ *	Dimensions — mm								
			A	B	C	D	E	F	G	LCH	MF
OSPE50B	0	AF	98.43	M6	85	73.03	3.0	12.70	37.0	76	15
	0	AE	98.43	M5	88	73.03	3.0	12.70	30.0	67	14
	0	B9	75.00	M5	75	60.00	2.5	14.00	30.0	67	14
	0	BA	75.00	M5	70	60.00	3.0	16.00	40.0	76	15
	0	B0	75.00	M6	75	60.00	3.0	14.00	30.0	67	14
	0	B2	90.00	M5	80	60.00	2.5	14.00	30.0	67	14
	0	BB	90.00	M6	80	70.00	3.0	14.00	30.0	67	14
	0	B4	90.00	M6	80	70.00	3.0	16.00	40.0	76	15
	0	AP	90.00	M6	80	70.00	3.0	19.00	40.0	76	15
	0	B3	95.00	M6	85	50.00	2.5	14.00	30.0	67	14
	0	A1	99.00	M6	88	73.00	3.0	9.525	31.5	67	14
	0	A3	100.00	M6	90	80.00	3.5	14.00	30.0	67	14
	0	AL	100.00	M6	88	80.00	3.0	16.00	40.0	76	15
	0	AJ	100.00	M6	88	80.00	3.0	19.00	40.0	76	15
	0	A4	115.00	M8	100	95.00	3.5	19.00	40.0	76	15
	0	BD	130.00	M8	115	95.00	3.0	19.00	40.0	76	15
	0	BF	130.00	M8	115	110.00	3.5	19.00	40.0	76	15

*When ordering with actuator, use order code ⑥ (gearhead designation) and order code ⑦ to specify motor mounting kit. See ordering information, page 48.

■ Blue order codes indicate rapid shipment availability

OSPE..B Belt-Driven Actuators

Mounted Motor Options



Mounted Motor Options include a coupling housing, coupling, flange and motor

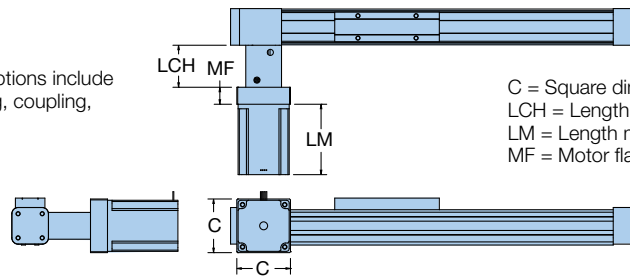

C = Square dimension
LCH = Length coupling housing
LM = Length motor
MF = Motor flange

Actuator Size	Order Code ⑥ *	Order Code ⑦ *	Motor description	Dimensions — mm			
				C	LCH	LM	MF
OSPE25B	0	KA	MPE0402A4E-KC1N	40	47	91	12
	0	L0	LV233-01-10	58	47	79	9
	0	L1	HV233-01-10	58	47	79	9
	0	K0	BE233FJ-KPSN	58	47	143	19
	0	K1	BE233FJ-KPSN with brake (CM233FJ-115027)	58	47	178	19
OSPE32B	0	L0	LV233-01-10	58	49	79	10
	0	L1	HV233-01-10	58	49	79	10
	0	L2	LV343-01-10	86	49	127	26
	0	L3	HV343-01-10	86	49	127	26
	0	KA	MPE0602A4E-KC1N	60	49	118	16
	0	K0	BE233FJ-KPSN	58	49	143	18
	0	K1	BE233FJ-KPSN with brake (CM233FJ-115027)	58	49	178	18
	0	K2	BE344LJ-KPSN	86	49	188	16
OSPE50B	0	K3	BE344LJ-KPSB	86	49	220	16
	0	L2	LV343-01-10	86	76	127	15
	0	L3	HV343-01-10	86	76	127	15
	0	KA	MPE0804A4E-KC1N	80	76	146	15
	0	K2	BE344LJ-KPSN	86	67	188	14
	0	K3	BE344LJ-KPSB	86	67	220	14
	0	M0	MPP0923D1E-KPSN	89	76	178	15
	0	M1	MPP0923D1E-KPSB	89	76	212	15
	0	M2	MPP1003D1E-KPSN	98	76	175	15
	0	M3	MPP1003D1E-KPSB	98	76	224	15
0	M4	MPP1003R1E-KPSN	98	76	175	15	
0	M5	MPP1003R1E-KPSB	98	76	224	15	

*When ordering with actuator, use order code ⑥ (gearhead designation) and order code ⑦ to specify mounted motor. See ordering information, page 48.

■ Blue order codes indicate rapid shipment availability

Gearhead Mounting Kit Options

Gearhead Mounting Kits include a coupling housing, coupling and flange

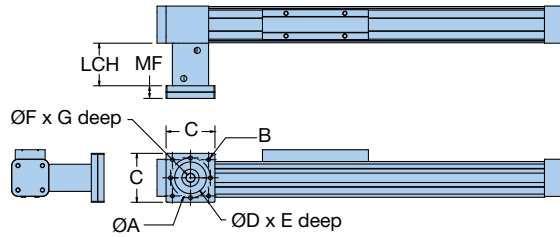

A = Bolt circle diameter
 B = Screw for bolt circle
 C = Square dimension
 D = Pilot diameter
 E = Pilot depth
 F = Input drive shaft diameter
 G = Input drive shaft length
 LCH = Length coupling housing
 MF = Motor flange

Actuator Size	Order Code ⑥ *	Order Code ⑦ *	Dimensions – mm								
			A	B	C	D	E	F	G	LCH	MF
OSPE25B	0	C0	44	S4	54	35	3	12	25	47	14.0
	0	C0	44	S4	60	35	3	12	25	49	14.5
OSPE32B	0	C1	62	S5	75	52	8	16	36	49	23.0
	0	C1	62	S5	75	52	8	16	36	76	18.5
OSPE50B	0	C2	80	S6	95	68	10	22	46	76	23.0

*When ordering with actuator, use order code ⑥ (gearhead designation) and order code ⑦ to specify gearhead mounting kit See ordering information, page 48.

■ Blue order codes indicate rapid shipment availability

OSPE..B Belt-Driven Actuators

Mounted Gearhead with Motor Mounting Kit Options

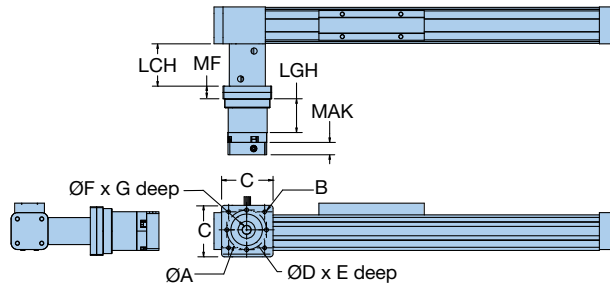

A = Bolt circle diameter
 B = Screw for bolt circle
 C = Square dimension
 D = Pilot diameter
 E = Pilot depth
 F = Input drive shaft diameter
 G = Input drive shaft length
 LCH = Length coupling housing
 LGH = Length gearhead
 MAK = Motor adapter
 MF = Motor flange

Mounted Gearhead with Motor Mounting Kit include a coupling housing, coupling, flange, and gearhead with coupler and flange

Actuator Size	Order Code ⑥ ¹	Order Code ⑦ ²	Dimensions – mm										
			A	B	C	D	E	F	G	LCH	LGH	MAK	MF
OSPE25B	A or B	AA	46.66	M3	43	20.00	1.6	6.35	24.8	47	48.5	19.0	14.0
	A or B	AB	66.67	M5	55	38.10	1.6	6.35	20.5	47	48.5	15.7	14.0
	A or B	B5	46.00	M4	43	30.00	2.5	6.00	25.0	47	48.5	19.0	14.0
	A or B	AM	46.00	M4	43	30.00	2.5	8.00	25.0	47	48.5	19.0	14.0
	A or B	B6	63.00	M4	55	40.00	2.5	9.00	20.0	47	48.5	13.7	14.0
	A or B	AH	63.00	M5	55	40.00	2.5	9.00	20.0	47	48.5	19.0	14.0
OSPE32B	C, D or E	AB	66.67	M5	62	38.10	1.6	6.35	20.5	49	67.0	16.5	23.0
	C, D or E	AC	66.67	M5	62	38.00	1.6	9.53	20.8	49	67.0	16.5	23.0
	C, D or E	AF	98.43	M6	85	73.03	3.0	12.70	37.0	49	67.0	30.0	23.0
	C, D or E	AD	66.67	M5	62	38.10	1.6	9.525	31.8	49	67.0	22.5	23.0
	C, D or E	AE	98.43	M5	80	73.03	3.0	12.70	30.0	49	67.0	22.5	23.0
	C, D or E	B6	63.00	M4	62	40.00	2.5	9.00	20.0	49	67.0	16.5	23.0
	C, D or E	AH	63.00	M5	62	40.00	2.5	9.00	20.0	49	67.0	16.5	23.0
	C, D or E	B8	70.00	M5	62	50.00	3.0	12.00	30.0	49	67.0	22.5	23.0
	C, D or E	AN	70.00	M5	62	50.00	3.0	14.00	30.0	49	67.0	22.5	23.0
	C, D or E	AG	75.00	M5	62	60.00	2.5	11.00	23.0	49	67.0	16.5	23.0
	C, D or E	B9	75.00	M5	62	60.00	2.5	14.00	30.0	49	67.0	22.5	23.0
	C, D or E	BB	90.00	M6	80	70.00	3.0	14.00	30.0	49	67.0	22.5	23.0
	C, D or E	A3	100.00	M6	89	80.00	3.5	14.00	30.0	49	67.0	22.5	23.0
	OSPE50B	C, D or E	AB	66.67	M5	62	38.10	1.6	6.35	20.5	76	67.0	16.5
C, D or E		AC	66.67	M5	62	38.00	1.6	9.53	20.8	76	67.0	16.5	18.5
C, D or E		AF	98.43	M6	85	73.03	3.0	12.70	37.0	76	67.0	30.0	18.5
C, D or E		AD	66.67	M5	62	38.10	1.6	9.525	31.8	76	67.0	22.5	18.5
C, D or E		AE	98.43	M5	80	73.03	3.0	12.70	30.0	76	67.0	22.5	18.5
C, D or E		B6	63.00	M4	62	40.00	2.5	9.00	20.0	76	67.0	16.5	18.5
C, D or E		AH	63.00	M5	62	40.00	2.5	9.00	20.0	76	67.0	16.5	18.5
C, D or E		B8	70.00	M5	62	50.00	3.0	12.00	30.0	76	67.0	22.5	18.5
C, D or E		AN	70.00	M5	62	50.00	3.0	14.00	30.0	76	67.0	22.5	18.5
C, D or E		AG	75.00	M5	62	60.00	2.5	11.00	23.0	76	67.0	16.5	18.5
C, D or E		B9	75.00	M5	62	60.00	2.5	14.00	30.0	76	67.0	22.5	18.5
C, D or E		BB	90.00	M6	80	70.00	3.0	14.00	30.0	76	67.0	22.5	18.5
C, D or E		A3	100.00	M6	89	80.00	3.5	14.00	30.0	76	67.0	22.5	18.5

¹ When ordering with actuator, use order code ⑥ to specify mounted gearhead size and ratio: **A** PV40TA-005 (ratio 5:1); **B** PV40TA-010 (ratio 10:1); **C** PV60TA-003 (ratio 3:1); **D** PV60TA-005 (ratio 5:1); **E** PV60TA-010 (ratio 10:1). See ordering information, page 48.
² When ordering with actuator, use order code ⑦ to specify motor mounting kit. See ordering information, page 48.

■ Blue order codes indicate rapid shipment availability

Mounted Gearhead and Motor Options

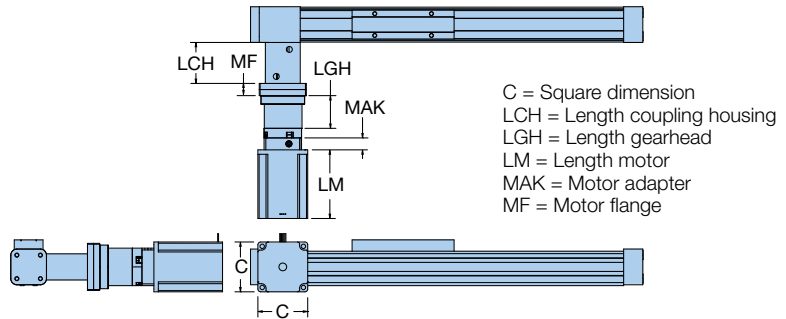

Mounted Gearhead and Mounted Motor Options include a coupling housing, coupling, flange, gearhead with coupler, flange and motor

Actuator Size	Order Code ⑥ ¹	Order Code ⑦ ²	Motor description	Dimensions – mm					
				C	LCH	LGH	LM	MAK	MF
OSPE25B	A or B	L0	LV233-01-10	58	47	48.5	79	15.7	14.0
	A or B	L1	HV233-01-10	58	47	48.5	79	15.7	14.0
	A or B	KA	MPE0402A4E-KC1N	40	47	48.5	91	19.0	14.0
OSPE32B	C, D or E	L0	LV233-01-10	58	49	67.0	79	16.5	23.0
	C, D or E	L1	HV233-01-10	58	49	67.0	79	16.5	23.0
	C, D or E	L2	LV343-01-10	86	49	67.0	127	30.0	23.0
	C, D or E	L3	HV343-01-10	86	49	67.0	127	30.0	23.0
	C, D or E	KC	MPE0602A4E-KC1N	60	49	67.0	118	22.5	23.0
	C, D or E	K0	BE233FJ-KPSN	58	49	67.0	143	22.5	23.0
	C, D or E	K1	BE233FJ-KPSN with brake (CM233FJ-115027)	58	49	67.0	178	22.5	23.0
	C, D or E	K2	BE344LJ-KPSN	86	49	67.0	188	22.5	23.0
OSPE50B	C, D or E	L0	LV233-01-10	58	76	67.0	79	16.5	18.5
	C, D or E	L1	HV233-01-10	58	76	67.0	79	16.5	18.5
	C, D or E	L2	LV343-01-10	86	76	67.0	127	30.0	18.5
	C, D or E	L3	HV343-01-10	86	76	67.0	127	30.0	18.5
	C, D or E	KC	MPE0602A4E-KC1N	60	76	67.0	118	22.5	18.5
	C, D or E	K0	BE233FJ-KPSN	58	76	67.0	143	22.5	18.5
	C, D or E	K1	BE233FJ-KPSN with brake (CM233FJ-115027)	58	76	67.0	178	22.5	18.5
	C, D or E	K2	BE344LJ-KPSN	86	76	67.0	188	22.5	18.5
	C, D or E	K3	BE344LJ-KPSB	86	76	67.0	220	22.5	18.5

¹ When ordering with actuator, use order code ⑥ to specify mounted gearhead size and ratio: **A** PV40TA-005 (ratio 5:1); **B** PV40TA-010 (ratio 10:1); **C** PV60TA-003 (ratio 3:1); **D** PV60TA-005 (ratio 5:1); **E** PV60TA-010 (ratio 10:1). See ordering information, page 48.

² When ordering with actuator, use order code ⑦ to specify mounted motor on gearhead. See ordering information, page 48.



■ Blue order codes indicate rapid shipment availability

OSPE..B Belt-Driven Actuators

End Cap Mounting Options

See "Maximum Permissible Unsupported Length" (page 46), for end cap mounting placement requirements.

End Cap Mounting Selection Overview

Type	Standard Carriage			PowerSlide						ProLine			
	25	32	50	25/25	25/35	25/44	32/35	32/44	50/60	50/76	25	32	50
Standard 	A1	•	•										
	A2										•	•	
	A3				•	•		•					
Reinforced 	B1	•	•	•	•	•	•	•			•	•	
	B4							•					
Block 	C1			•									•
	C2												•
	C3								•				
	C4									•			

• Recommended for mounting position with carriage on top • Recommended for mounting position carriage side only (3 or 9 o'clock position)

Order Code

1, 2 or 3
(1 pair)

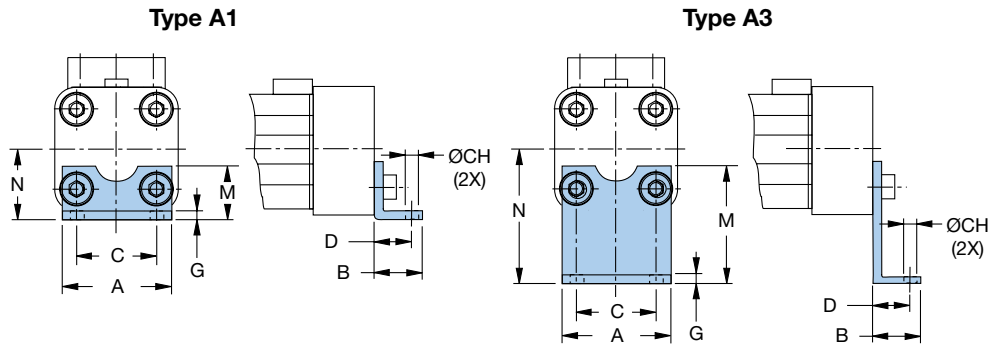

Type A1, A2 and A3 – Standard End Cap

Actuator Size	Type	Part Number*	Weight* (kg)	Dimensions – mm								
				A	B	C	CH	D	G	M	N	
OSPE25B	A1	18156FIL	0.031								18	22
	A2	18157FIL	0.044	39	22	27	5.8	16	2.5		33	37
	A3	18158FIL	0.055								45	49
OSPE32B	A1	18161FIL	0.050								20	30
	A2	18162FIL	0.066	50	26	36	6.6	18	3.0		34	44
	A3	18163FIL	0.159								42	52

*Part number and weight are for individual piece.

Order
Code

4 or 5
(1 pair)

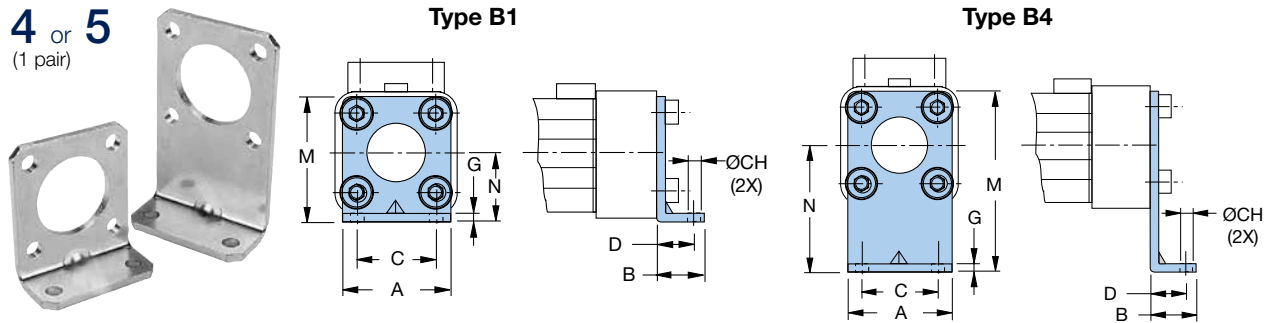

Type B1 and B4 – Reinforced End Cap

Actuator Size	Type	Part Number*	Weight* (kg)	Dimensions – mm							
				A	B	C	CH	D	G	M	N
OSPE25B	B1	18159FIL	0.010	39	22	27	5.8	16	2.5	42	22
	B4	18160FIL	0.110							80	60
OSPE32B	B1	18164FIL	0.078	50	26	36	6.6	18	3.0	55	30
	B4	18165FIL	0.380							85	60

*Part number and weight are for individual piece.

Order
Code

1, 2, 3 or 4
(1 pair)

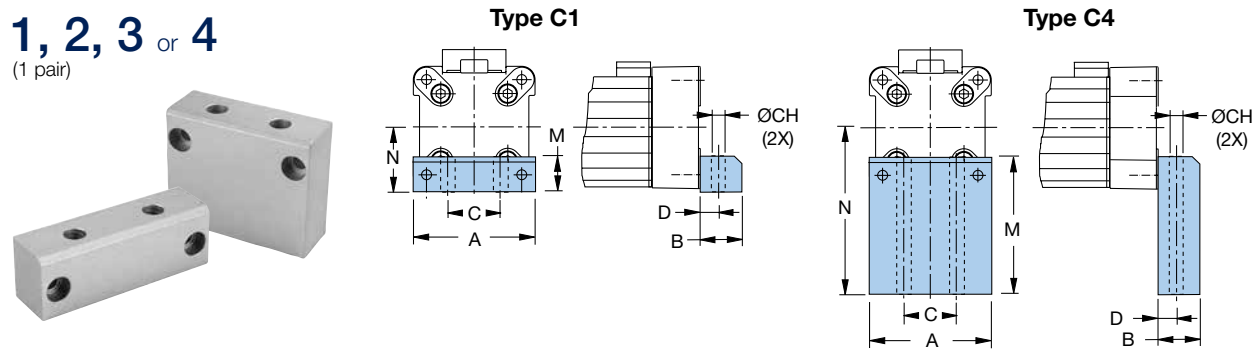

Type C1, C2, C3 and C4 – Block End Cap

Actuator Size	Type	Part Number*	Weight* (kg)	Dimensions – mm							
				A	B	C	CH	D	M	N	
OSPE50B	C1	18166FIL	0.146							30	48
	C2	18167FIL	0.210							39	57
	C3	18168FIL	0.300	86	24	40	9.0	12.5		54	72
	C4	18169FIL	0.412							77	95



*Part number and weight are for individual piece.

OSPE..B Belt-Driven Actuators

Profile Mounting Options

See "Maximum Permissible Unsupported Length" (page 46), for end cap and profile mounting placement requirements.

Profile Mounting Selection Overview

Type	Standard Carriage			PowerSlide							ProLine		
	25	32	50	25/25	25/35	25/44	32/35	32/44	50/60	50/76	25	32	50
 2 Internal Threads D1													
 2 Thru Holes E1 E2 E3 E4													
 3 Thru Holes MAE													

• Recommended for mounting position with carriage on top • Recommended for mounting position carriage side only (3 or 9 o'clock position)

Order Code

2, 5 or 8
(1, 2 or 3 pair)

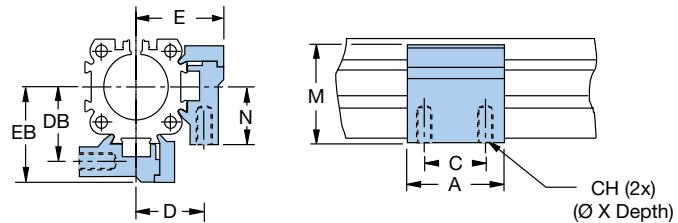

Type D1 (with two internal threads)

Actuator Size	Part Number*	Weight* (kg)	Dimensions — mm								
			A	C	CH	D	DB	E	EB	M	N
OSPE25B	20008FIL	0.061	50	36	M5 x 10	27	28.5	34.5	36	38	22
OSPE32B	20157FIL	0.072	50	36	M5 x 10	33	35.5	40.5	43	46	30
OSPE50B	20162FIL	0.167	60	45	M6 x 11	40	45.0	52.0	57	71	48

*Part number and weight are for individual piece.

Order Code

E1 **1, 4** or **7** (1, 2 or 3 pair) E3 **L, P** or **S** (1, 2 or 3 pair)
 E2 **K, N** or **R** (1, 2 or 3 pair) E4 **M, Q** or **T** (1, 2 or 3 pair)

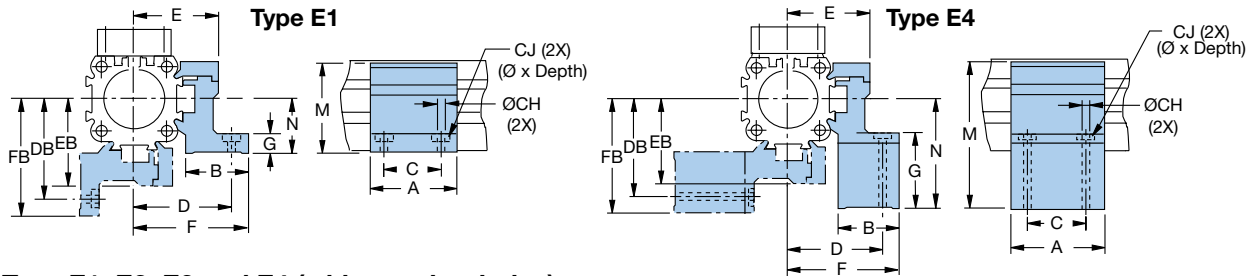

Type E1, E2, E3 and E4 (with two thru holes)

Actuator Size	Part Number*	Weight* (kg)	Dimensions — mm														
			A	B	C	CH	CJ	D	DB	E	EB	F	FB	G	M	N	
OSPE25B	E1 20009FIL	0.074													8	38	22
	E2 20352FIL	0.125	50	26	36	5.5	10 x 5.7	40	41.5	34.5	36	47.5	49	23	53	37	
	E3 20353FIL	0.120												35	65	49	
	E4 20354FIL	0.020												46	76	60	
OSPE32B	E1 20158FIL	0.092												10	46	30	
	E2 20355FIL	0.141	50	27	36	5.5	10 x 5.7	46	48.5	40.5	43	54.5	57	24	60	44	
	E3 20356FIL	0.140												32	68	52	
	E4 20357FIL	0.197												40	76	60	
OSPE50B	E1 20163FIL	0.189												10	71	48	
	E2 20361FIL	0.235	60	34	45	7.0	—	59	64.0	52.0	57	67.0	72	19	80	57	
	E3 20362FIL	0.338												31	95	72	
	E4 20363FIL	0.442												57	118	95	

*Part number and weight are for individual piece.

Order Code

3, 6 or **9**
(1, 2 or 3 pair)

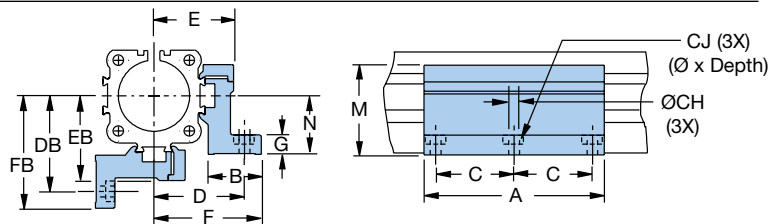

Type MAE (with three thru holes)

Actuator Size	Part Number*	Weight* (kg)	Dimensions — mm													
			A	B	C	CH	CJ	D	DB	E	EB	F	FB	G	M	N
OSPE25B	12278FIL	0.271	92	26	40	5.5	10 x 5.7	40	41.5	34.5	36	47.5	49	8	38	22
OSPE32B	12279FIL	0.334	92	27	40	5.5	10 x 5.7	46	48.5	40.5	43	54.5	57	10	46	30
OSPE50B	12280FIL	0.668	112	34	45	7.0	—	59	64.0	52.0	57	67.0	72	10	71	48

*Part number and weight are for individual piece.

OSPE..B Belt-Driven Actuators

Maximum Permissible Unsupported Length — Determining end cap and profile mounting placement

OSPE..B Series actuators need to be mounted onto a solid machine base or frame structure using appropriately positioned end cap and profile mounts. This ensures that the actuator will not undergo excessive deflection based on the application's load and length requirements.

The greater the load and/or the longer the unsupported length between mounts, the more the actuator is susceptible to deflection. Deflection is also dependent on the carriage orientation (F_z for top oriented carriage or F_y for a side mounted carriage).

Standard Carriage, Tandem Carriage, PowerSlide or ProLine

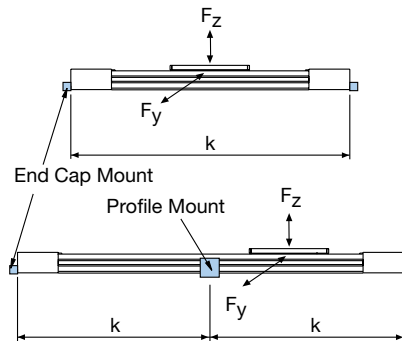

To determine correct end cap and profile mount placement, please follow the steps shown in the example below.

Bi-Parting Carriage

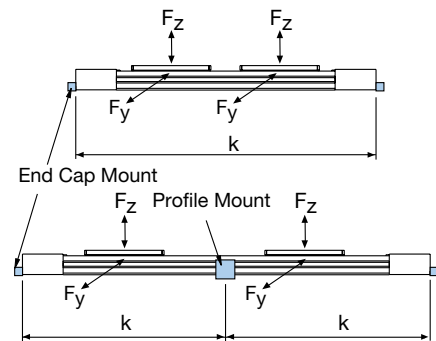

Use the deflection graphs (page 47), to ensure that the load will not exceed the maximum allowed deflection.

Example:

A horizontal application uses an OSPE32B with a top oriented carriage. The maximum load to the carriage is 10 kg and the order stroke is 3,700 mm (see page 32 to calculate order stroke).

Therefore, the overall length of the actuator will be 4,000 mm:

$$3,700 \text{ mm} + 2 \times \text{Dim "X"} (150 \text{ mm}) = 4,000 \text{ mm}$$

- 1) Use the appropriate F_z graph (page 47) for a top loaded carriage. (Note: with the standard carriage, top loaded F_z and side loaded F_y values are the same).
- 2) Calculate the Load "F" in Newtons based on the 10 kg application load requirement:

$$10 \text{ kg} \times 9.81 \text{ kg/ms}^2 = 98.1 \text{ N}$$

- 3) Draw a line from 98 N on the Y-axis to the OSPE32B curve, then down to the X-axis.
- 4) The value of "k" is approximately 3,600 mm.
- 5) Since the overall length (4,000 mm) is greater than this value "k", the actuator will require an additional third fixture point — two end cap mounts and one profile mount — equally spaced to create a distance "k" of 2000 mm in between.
- 6) Maximum deflection of the actuator with this mounting configuration will be less than 4 mm:

$$0.2\% \text{ of } 2,000 \text{ mm} = 4 \text{ mm}$$

Standard Carriage Load-Distance

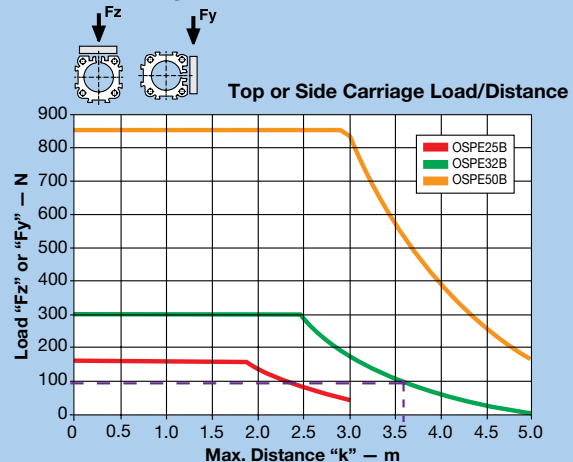

To further reduce deflection:

If the application requires less deflection, then simply reduce the distance "k" appropriately. In this example, for instance, the application must not exceed 2 mm (1/2 the maximum deflection calculated). Therefore, "k" must also be 1/2, or 1000 mm.

To achieve this reduced maximum deflection, the actuator will require five fixture points — two end cap mounts and three profile mounts — equally spaced with a distance "k" of 1000 mm in between.

Standard Carriage Load-Distance

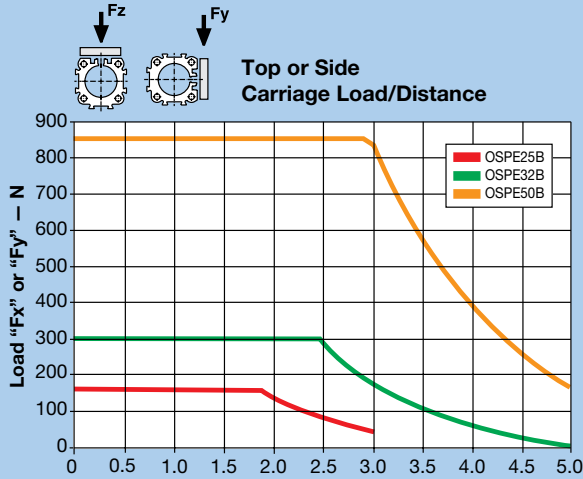

Maximum Permissible Unsupported Length

Determining end cap and profile mounting placement

Use the appropriate deflection graph to ensure that the application load does not exceed the deflection curve. Supporting the actuator within the recommended maximum distance "k" will ensure that the installation will have a maximum deflection equal to 0.2% of distance "k."

To further reduce deflection, simply reduce the distance between end cap and profile mounts as described in the example on the previous page.

PowerSlide Carriage Load-Distance

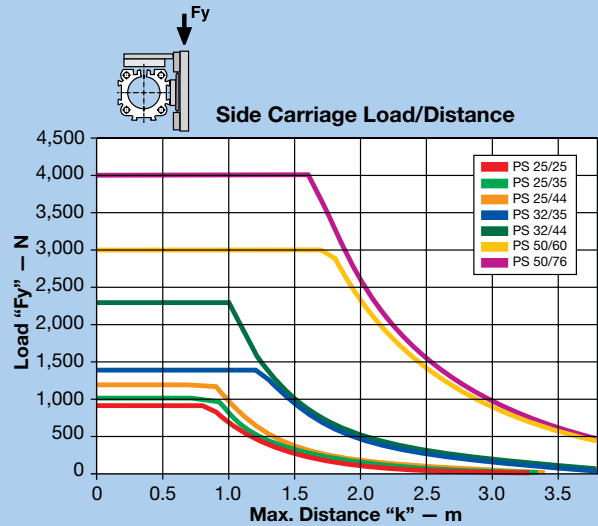
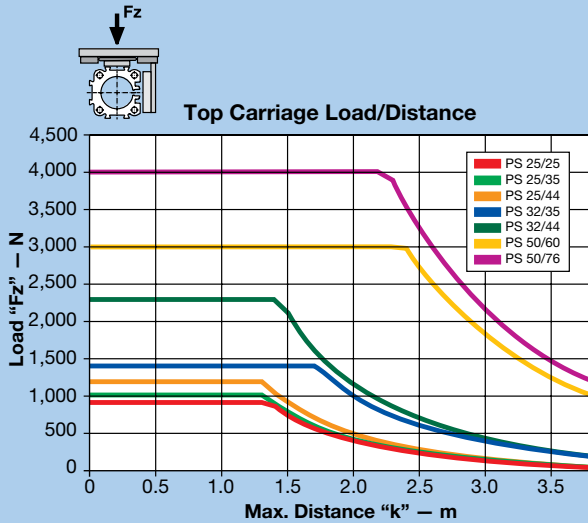

ProLine Carriage Load-Distance

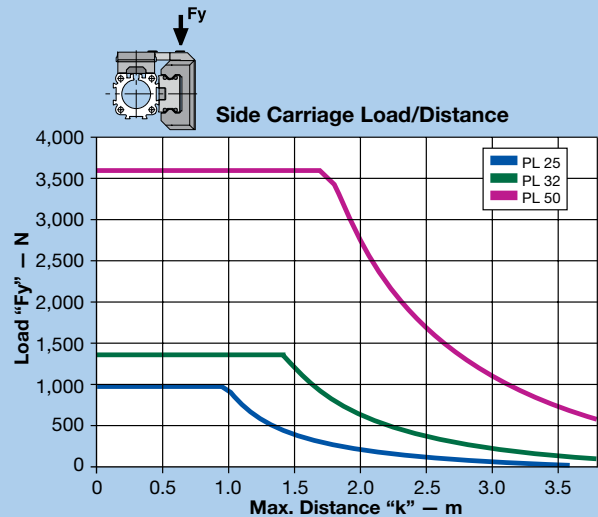
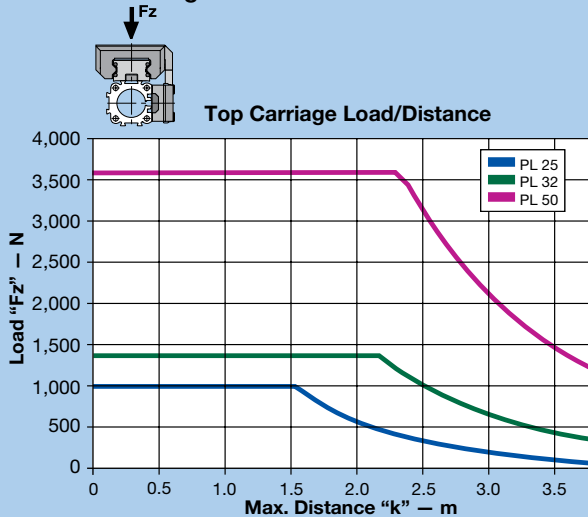

OSPE..B Belt-Driven Actuators

Ordering Information

Select an order code from each of the numbered fields to create a complete OSPE..B model order number. Include hyphens and non-selective characters as shown in example below.

① ② ③ ④ ⑤ ⑥ ⑦ ⑧ ⑨ ⑩ ⑪ ⑫ ⑬ ⑭

Order Number Example: OSPE 25 - 0 0 0 0 0 - 00000 - P 0 0 0 0 0

① Series

OSPE Origa System Plus Electromechanical

② Actuator Bore Size

25 41 mm W x 53 mm H

32 52 mm W x 67 mm H

50 87 mm W x 93 mm H

③ Drive Train

0 Belt actuator with internal glider bearing

④ Carriage

0 Standard

1 Tandem (two carriages for higher load capabilities)

2 Bi-Parting (two driven carriages for opposing movements)

⑤ Drive Shaft and Motor Input

0  Plain shaft, motor input left

1  Plain shaft, motor input right

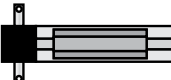
2  Double plain shaft, motor input left

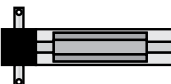
3  Double plain shaft, motor input right

⑥ Mounted Gearhead Options

0 No gearhead

A PV40TA-005 (gear ratio 5:1)*

B PV40TA-010 (gear ratio 10:1)*

C PV60TA-003 (gear ratio 3:1)*

D PV60TA-005 (gear ratio 5:1)*

E PV60TA-010 (gear ratio 10:1)*

* Requires selection from "Mounted Gearhead with Motor Mounting Kit" (see page 40), or "Mounted Gearhead and Motor" (see page 41) for item ⑦ below.

⑦ Gearhead/Motor Mounting Options:

0 - No gearhead or motor mounting option

Motor Mounting Kits (see page 36 for available option dimensions and delivery)

Mounted Motors (see page 38 for available option dimensions and delivery)

Gearhead Mounting Kits (see page 39 for available option dimensions and delivery)

Mounted Gearhead with Motor Mounting Kit (see page 40 for available option dimensions and delivery)

Mounted Gearhead and Motor (see page 41 for available option dimensions and delivery)

⑧ Order Stroke*

00000 5-digit input (in mm)

* See page 32 to calculate required order stroke.

Maximum catalog stroke:

OSPE25B = 03000 mm;

OSPE32B and OSPE50B = 05000 mm

Longer strokes available upon request. Consult factory.

⑨ Hardware and Dovetail Groove Covers

P Standard hardware with Parker gold cover strip

■ Blue order codes indicate rapid shipment availability



⑩ Carriage Options

0	No external guide rail
6	ProLine PL25, PL32, PL50*
E	PowerSlide PS25/25*
F	PowerSlide PS25/35 or PS32/35*
G	PowerSlide PS25/44 or PS32/44*
H	PowerSlide PS50/60*
I	PowerSlide PS50/76*
M	Inversion Mounting**
R	Clevis Mounting **

* Requires standard carriage (select order code "0" from ④). See page 31 for dimensions and additional information.

** Requires standard carriage (select order code "0" from ④). See page 35 for Inversion Mounting and page 34 for Clevis Mounting.

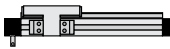
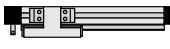
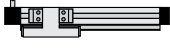
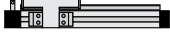
⑪ External Guide Rail Orientation

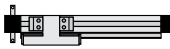
0		Guide Rail (right) with order code "0" from item ⑤ (plain shaft left)
1		Guide Rail (left) with order code "0" from item ⑤ (plain shaft left)
0		Guide Rail (left) with order code "1" from item ⑤ (plain shaft right)
1		Guide Rail (right) with order code "1" from item ⑤ (plain shaft right)
0		Guide Rail (right) with order code "2" from item ⑤ (double shaft – motor input left side)
1		Guide Rail (left) with order code "2" from item ⑤ (double shaft – motor input left side)

⑫ End Cap Mounting (see page 42)

0	No end cap mounting
1	1 pair A1* (standard end cap) or C1** (block end cap)
2	1 pair A2* (standard end cap) or C2** (block end cap)
3	1 pair A3* (standard end cap) or C3** (block end cap)
4	1 pair B1* (reinforced end cap) or C4** (block end cap)
5	1 pair B4* (reinforced end cap)

* For size 25 and 32

** For size 50

⑬ Profile Mounting (see page 44)

0	No profile mounting
2	1 pair D1 (with 2 internal threads)
5	2 pair D1 (with 2 internal threads)
8	3 pair D1 (with 2 internal threads)
1	1 pair E1 (with 2 thru holes)
4	2 pair E1 (with 2 thru holes)
7	3 pair E1 (with 2 thru holes)
3	1 pair MAE (with 3 thru holes)
6	2 pair MAE (with 3 thru holes)
9	3 pair MAE (with 3 thru holes)
K	1 pair E2 (with 2 thru holes)
N	2 pair E2 (with 2 thru holes)
R	3 pair E2 (with 2 thru holes)
L	1 pair E3 (with 2 thru holes)
P	2 pair E3 (with 2 thru holes)
S	3 pair E3 (with 2 thru holes)
M	1 pair E4 (with 2 thru holes)
Q	2 pair E4 (with 2 thru holes)
T	3 pair E4 (with 2 thru holes)

⑭ Magnetic Sensor Mounting*

0	No sensor mounting
A	1 pc. N.O., NPN, with M8 connector
B	2 pc. N.C., NPN, with M8 connector
C	1 pc. N.O., NPN, with M8 connector 2 pc. N.C., NPN, with M8 connector
D	1 pc. N.O., PNP, with M8 connector
E	2 pc. N.C., PNP, with M8 connector
F	1 pc. N.O., PNP, with M8 connector 2 pc. N.C., PNP, with M8 connector

* Extension cable with M8 connector and 5 m cable flying lead cable for Sensor with M8 plug can be ordered separately; use part number 003-2918-01

■ Blue order codes indicate rapid shipment availability

OSPE..SB/ST Screw-Driven Actuators

OSPE..SB Ball Screw Actuators for Precise Positioning

OSPE..ST Trapezoidal Screw Actuators for Zero Backdrive

The field-proven OSPE..SB/ST design is the industry standard for medium precise positioning with a ball screw or intermitted duty positioning without back-drive with a trapezoidal screw. Compact size and maximum configurability make the OSPE..SB/ST easy to integrate into any machine layout simply and neatly.

The OSPE..SB design utilizes a ball screw which is ideal for medium precise applications requiring a 50 micron unidirectional repeatability. A ball screw is used in machines requiring reliable positioning with continuous and medium to high thrust force output at 100% duty cycle.

The OSPE..ST design utilizes a trapezoidal screw, which is ideal for low-speed and high-thrust applications with a maximum duty cycle of 10%. The trapezoidal screw has no back drive and therefore can hold loads in position without a motor brake, even in vertical orientations.



Advantages:

- Medium precise and highly repeatable position control
- High thrust force output
- Easy installation
- Excellent low speed characteristics
- No back-drive with OSPE..ST

Features:

- Integrated drive train and glider bearing
- Complete motor, gearhead and control packages
- Diverse range of accessories and mountings
- Clean room option on request
- Ambient temperature range -20°C to +80°C
- IP 54 rated

PowerSlide

- Designed for harsh environments
- Hardened steel guide rail
- Carriage with steel v-wheels
- Tough roller cover with wiper and grease access point

ProLine

- Designed for high-speed, precise, smooth and quiet operation
- Aluminum rail with ground and calibrated steel trucks
- Carriage supported by needle bearing rolls
- Integrated wipers to keep bearing system clean
- Lifetime lubricated bearing system

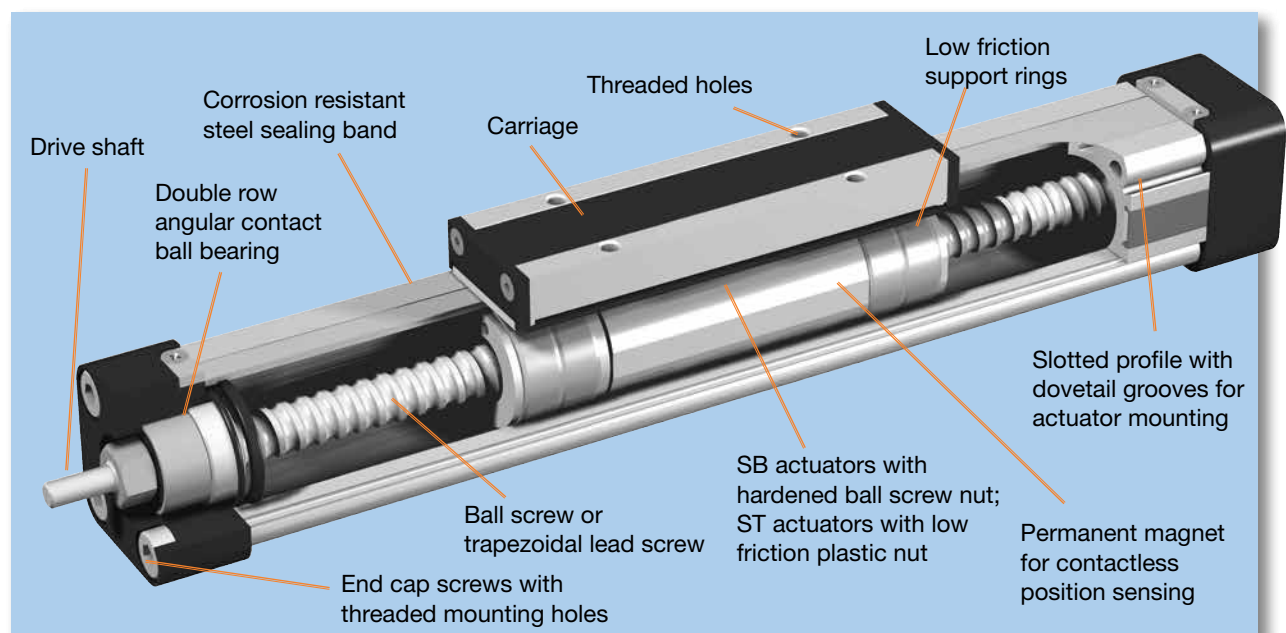

Choose from a Wide Range of Standard Options for Maximum Design Flexibility in a Pre-assembled Solution

Carriage Bearing Design Configurations



Standard carriage — with internal glider bearing



PowerSlide — externally mounted steel roller guide for higher load capabilities specifically in harsh environments



ProLine - externally mounted aluminum roller guide for higher load capabilities and precision positioning

Carriage Options



Standard



Tandem carriage — for higher load capabilities (OSPE..SB only)

Carriage Mounting



Standard



Clevis mounting — provides compensation between actuator and guide rails in machine designs

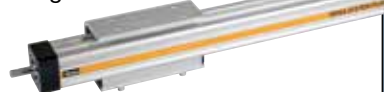

Inversion mounting — allows outer band to be on the bottom, while keeping payload on top, for better actuator protection in dirty environments

Multi-axis Systems

A wide range of adapter plates and intermediate drive shafts simplifies engineering and installation. Please consult factory for your individual system design.

Market Specific Options



Cleanroom version — Specific scraper system and vacuum suction ports to operate in clean environments (OSPE..SB only). Certified according to DIN EN ISO 146441-1. Please consult factory for more information.

Actuator Mounting Options



End cap mounting — allows the actuator to be anchored by the end caps



Profile mounting — supports long travel actuators or for direct mounting

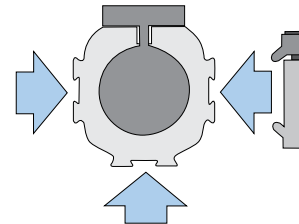

Options and Accessories



Information on all OSPE..SB/ST Series options are detailed on the following pages. Simply select all the options needed to solve your application requirements, then order with the actuator using convenient order codes (see last pages of the OSPE..SB/ST section). To order an option separately as an upgrade to an existing system or as a replacement part, use the individual option part numbers provided.

OSPE..SB/ST Screw-Driven Actuators

General Specifications

Actuator Size			OSPE25		OSPE32			OSPE50			
Screw Type (SB-Ball; ST-Trapezoidal)			SB	ST	SB	SB	ST	SB	SB	SB	ST
Screw Lead	s_{lin}	mm	5	4	5	10	4	5	10	25	6
Screw diameter		mm	12	16	16	16	20	25	25	25	30
Duty cycle*		%	100	10	100	100	10	100	100	100	10
Efficiency	η	%	90	40	90	90	40	90	90	90	40
Linear Speed (Max)	v_{max}	mm/s	250	100	250	500	100	250	500	1,250	150
Radial Speed (Max)		rpm	3,000	1,500	3,000	3,000	1,500	3,000	3,000	3,000	1,500
Acceleration (Max)	a_{max}	m/s ²	2	2	2	4	2	2	4	10	2
Repeatability (unidirectional)		μ m	± 50	± 500	± 50	± 50	± 500	± 50	± 50	± 50	± 500
Thrust Force (Max)	F_{Amax}	N	250	600	1,100	800	1,300	1,300	1,450	1,350	2,500
		lbs	56	135	247	180	292	292	326	303	562
Torque on Drive Shaft (Max)	M_{Amax}	Nm	0.4	1.3	1.2	1.7	2.5	1.5	3.1	6.7	6.6
		in-lb	3.7	11.1	10.4	15.2	21.9	13.7	27.1	59.0	58.1
Inertia											
@ Zero Stroke	J_0	kgmm ²	2	6	8	8	22	84	84	84	152
Per Meter of Stroke	J_{OS}	kgmm ² /m	11.0	30.0	32.0	32.0	81.0	225.0	225.0	225.0	400.0
Per 1 kg Moved Mass	J_m	kgmm ² /kg	0.6	0.4	0.6	2.5	0.4	0.6	2.5	15.8	0.9
Ambient Temperature Range		°C	-20 to +80 (OSPE..SB); -20 to +70 (OSPE..ST)								
IP Rating			IP 54								

* Due to the friction between the plastic nut and trapezoidal screw, the duty cycle must not exceed 10% to avoid early wear and increased noise emission.

Calculating Load Factors - Combined Normal and Moment Load

The sum of combined loads (static and dynamic) must not exceed "1" at any time as shown in the formula below:

$$\frac{F_z}{F_z(\max)} + \frac{M_x}{M_x(\max)} + \frac{M_y}{M_y(\max)} + \frac{M_z}{M_z(\max)} \leq 1$$

$$M = F \times l \text{ (Nm)}$$

$$M_x = M_{x \text{ static}} + M_{x \text{ dynamic}}$$

$$M_y = M_{y \text{ static}} + M_{y \text{ dynamic}}$$

$$M_z = M_{z \text{ static}} + M_{z \text{ dynamic}}$$

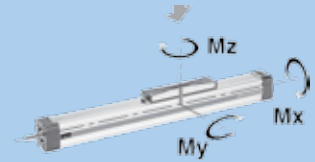

OSPE25SB/ST Performance

Carriage (Bearing System)			Standard Carriage		PowerSlide			ProLine	
			SB	ST	PS25/25	PS25/35	PS25/44	PL32	
Part Number ¹			—	—	20015	20016	20017	20856	
Max Order Stroke ²	OS_{max}	mm	1100	1100	1100	1100	1100	1100	
Normal Load ³ (Max)	F_Y / F_Z	N (lbs)	500 (112)	500 (112)	197 (44)	219 (49)	387 (87)	1549 (348)	
	M_X		2 (18)	2 (18)	3 (27)	4 (35)	6 (53)	30 (266)	
Moment Load ³ (Max)	M_Y	Nm (in-lb)	12 (106)	24 (212)	14 (124)	15 (133)	57 (504)	69 (611)	
	M_Z		8 (71)	7 (62)	14 (124)	15 (133)	57 (504)	69 (611)	
	Torque — SB — 5 mm lead	M_0	Nm (in-lb)	0.2 (1.8)	—	0.3 (2.7)	0.3 (2.7)	0.3 (2.7)	0.3 (2.7)
No Load ⁴ ST — 4 mm lead	M_0	—		0.3 (2.7)	0.4 (3.5)	0.4 (3.5)	0.4 (3.5)	0.4 (3.5)	
Weight	SB	@ 0 Stroke	m_0	0.6 (1.32)	—	0.9 (1.98)	1.0 (2.20)	1.2 (2.64)	0.8 (1.76)
		Per Meter of Stroke	m_{OS}	2.3 (5.06)	—	3.7 (8.14)	4.1 (9.02)	4.9 (10.78)	4.0 (8.80)
		Carriage ⁴	m_C	0.2 (0.44)	—	0.9 (1.98)	1.0 (2.20)	1.7 (3.74)	1.0 (2.20)
	ST	@ 0 Stroke	m_0	—	0.7 (1.54)	1.0 (2.20)	1.1 (2.42)	1.3 (2.86)	0.9 (1.98)
		Per Meter of Stroke	m_{OS}	—	1.6 (3.52)	4.2 (9.24)	4.6 (10.12)	5.4 (11.88)	4.5 (9.90)
		Carriage ⁴	m_C	—	0.2 (0.44)	0.9 (1.98)	1.0 (2.20)	1.7 (3.74)	1.0 (2.20)

OSPE32SB/ST Performance

Carriage (Bearing System)			Standard Carriage		PowerSlide		ProLine	
			SB	ST	PS32/35	PS32/44	PL32	
Part Number ¹			—	—	20286	20287	20857	
Max Order Stroke ²	OS _{max}	mm	2000	2000	2000	2000	2000	
Normal Load ³ (Max)	F _Y / F _Z	N (lbs)	1200 (270)	1000 (225)	303 (68)	747 (168)	2117 (476)	
Moment Load ³ (Max)	M _X	Nm (in-lb)	8 (71)	6 (53)	4 (35)	16 (142)	52 (460)	
	M _Y		25 (221)	65 (575)	15 (133)	57 (504)	132 (1168)	
	M _Z		16 (142)	12 (106)	15 (133)	57 (504)	132 (1168)	
Torque — No Load ⁴	SB – 5 mm lead	M ₀	0.3 (2.7)	—	0.4 (3.5)	0.4 (3.5)	0.4 (3.5)	
	SB – 10 mm lead	M ₀	0.4 (3.5)	—	0.5 (4.4)	0.5 (4.4)	0.5 (4.4)	
	ST – 4 mm lead	M ₀	—	0.6 (5.3)	0.7 (6.2)	0.7 (6.2)	0.7 (6.2)	
Weight	@ 0 Stroke	m ₀	1.6 (3.52)	—	2.0 (4.40)	2.2 (4.84)	2.1 (4.62)	
	SB	Per Meter of Stroke	m _{OS}	4.4 (9.68)	—	6.3 (13.86)	7.0 (15.40)	7.0 (15.40)
		Carriage ⁴	m _C	0.4 (0.88)	—	1.2 (2.64)	1.9 (4.18)	1.6 (3.52)
		@ 0 Stroke	m ₀	—	1.6 (3.52)	2.6 (5.72)	2.8 (6.16)	2.1 (4.62)
	ST	Per Meter of Stroke	m _{OS}	—	5.0 (11.00)	6.9 (15.18)	7.6 (16.72)	7.6 (16.72)
		Carriage ⁴	m _C	—	0.5 (1.10)	1.3 (2.86)	2.0 (4.40)	1.7 (3.74)

OSPE50SB/ST Performance

Carriage (Bearing System)			Standard Carriage		PowerSlide		ProLine	
			SB	ST	PS50/60	PS50/76	PL50	
Part Number ¹			—	—	20288	20289	20859	
Max Order Stroke ²	OS _{max}	mm	2000	2000	2000	2000	2000	
Normal Load ³ (Max)	F _Y / F _Z	N (lbs)	3000 (674)	1500 (337)	975 (219)	1699 (382)	5626 (1265)	
Moment Load ³ (Max)	M _X	Nm (in-lb)	16 (142)	13 (115)	29 (257)	59 (522)	201 (1779)	
	M _Y		80 (708)	155 (1372)	81 (717)	149 (1319)	451 (3992)	
	M _Z		32 (283)	26 (230)	81 (717)	149 (1319)	451 (3992)	
Torque — No Load ⁴	SB – 5 mm lead	M ₀	0.6 (5.3)	—	0.8 (7.1)	0.8 (7.1)	0.8 (7.1)	
	SB – 10 mm lead	M ₀	0.7 (6.2)	—	0.9 (8.0)	0.9 (8.0)	0.9 (8.0)	
	SB – 25 mm lead	M ₀	0.9 (8.0)	—	1.2 (10.6)	1.2 (10.6)	1.2 (10.6)	
	ST – 6 mm lead	M ₀	—	1.7 (15.0)	1.9 (16.8)	1.9 (16.8)	1.9 (16.8)	
Weight	@ 0 Stroke	m ₀	4.0 (8.80)	—	5.2 (11.44)	5.9 (12.98)	5.2 (11.44)	
	SB	Per Meter of Stroke	m _{OS}	9.4 (20.68)	—	13.6 (29.92)	16.0 (35.20)	13.2 (29.04)
		Carriage ⁴	m _C	1.2 (2.64)	—	3.5 (7.70)	6.1 (13.42)	3.7 (8.14)
		@ 0 Stroke	m ₀	—	3.8 (8.36)	5.0 (11.00)	5.7 (12.54)	5.0 (11.00)
	ST	Per Meter of Stroke	m _{OS}	—	10.6 (23.32)	14.8 (32.56)	17.2 (37.84)	14.4 (31.68)
		Carriage ⁴	m _C	—	1.3 (2.86)	3.6 (7.92)	6.2 (13.64)	3.8 (8.36)

¹ PowerSlide or ProLine bearings can be ordered individually with assigned part number in the table and specified, five digit order stroke value (mm), following the part number (-nnnn) to designate the appropriate length guide rail. To order PowerSlide or Proline bearing with the actuator, use the appropriate order code in item ⑩ on page 73.

² Longer strokes available upon request. Contact factory.

³ Load and moment based on 8000 km performance Refer to "Calculating Load Factors" on facing page for additional information.

⁴ For tandem option (OSPE..SB), double the values listed.

OSPE..SB/ST Screw-Driven Actuators

Life Performance

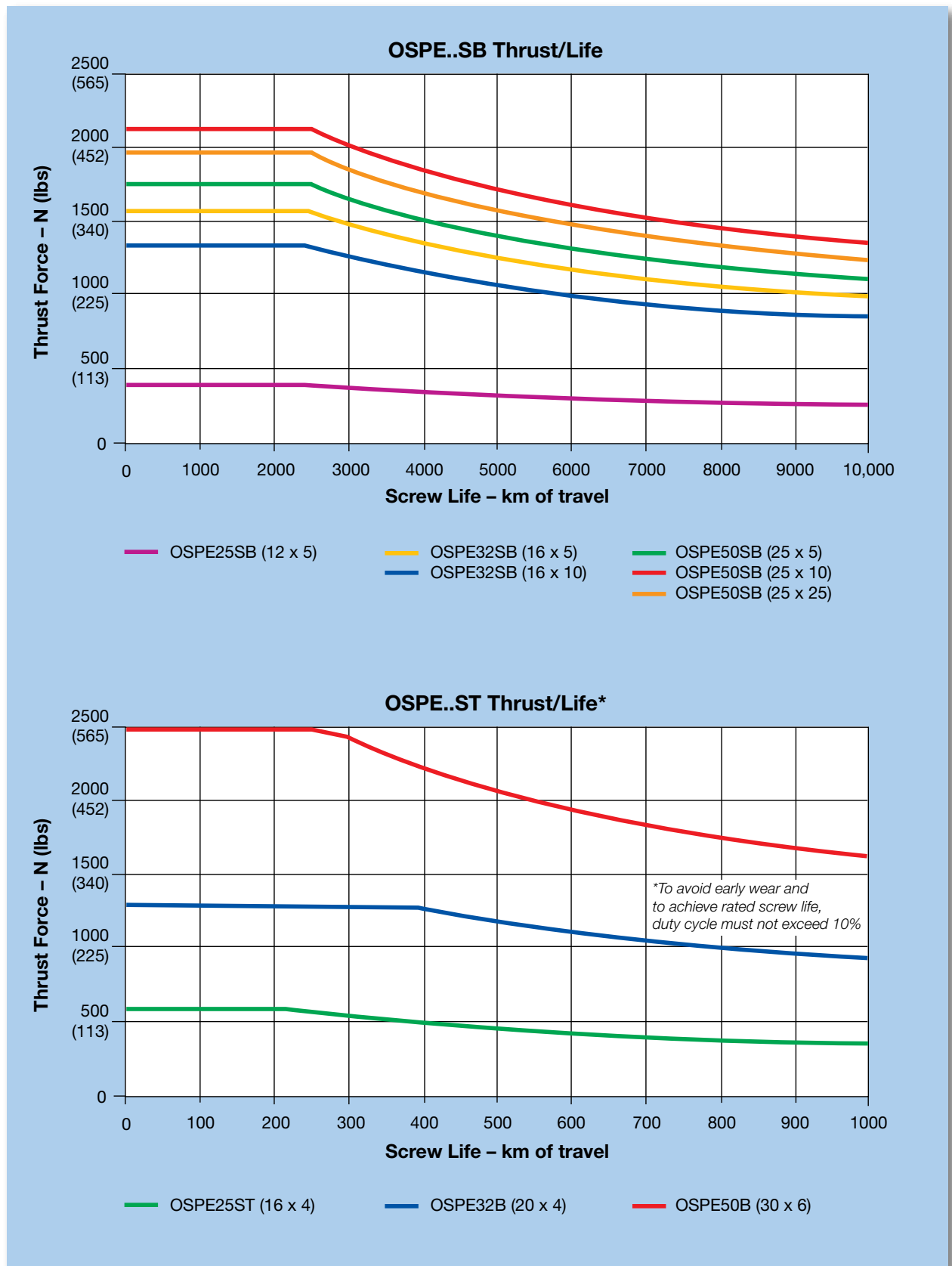

Speed Performance

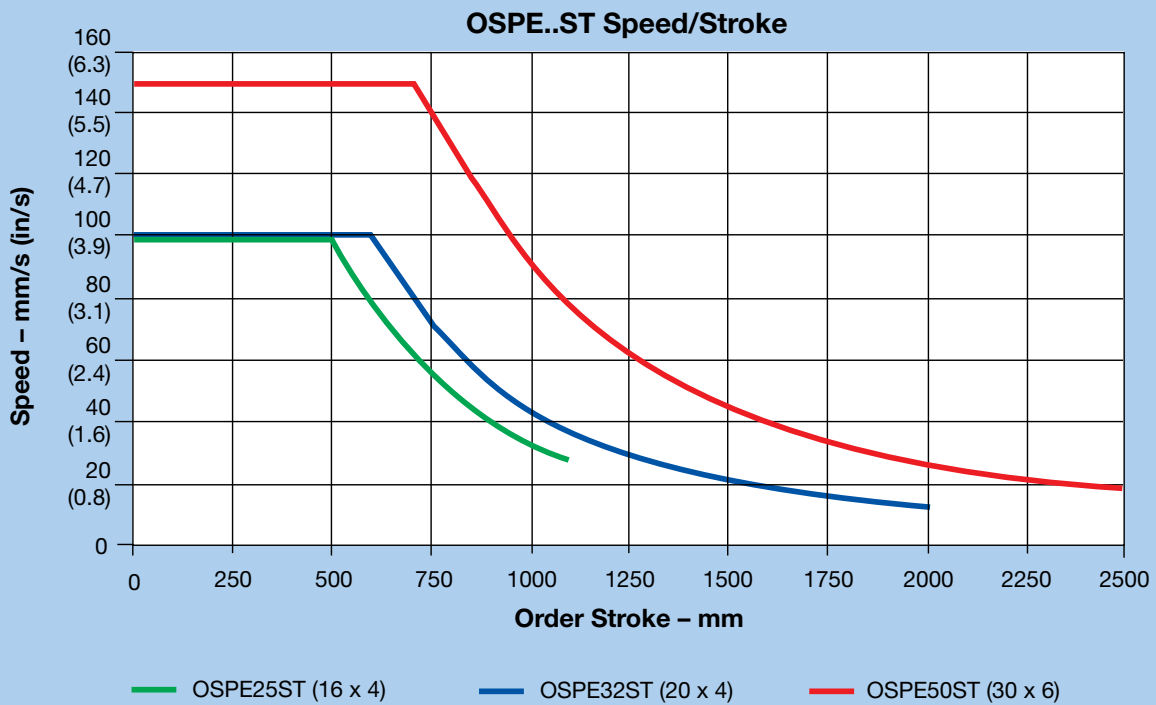
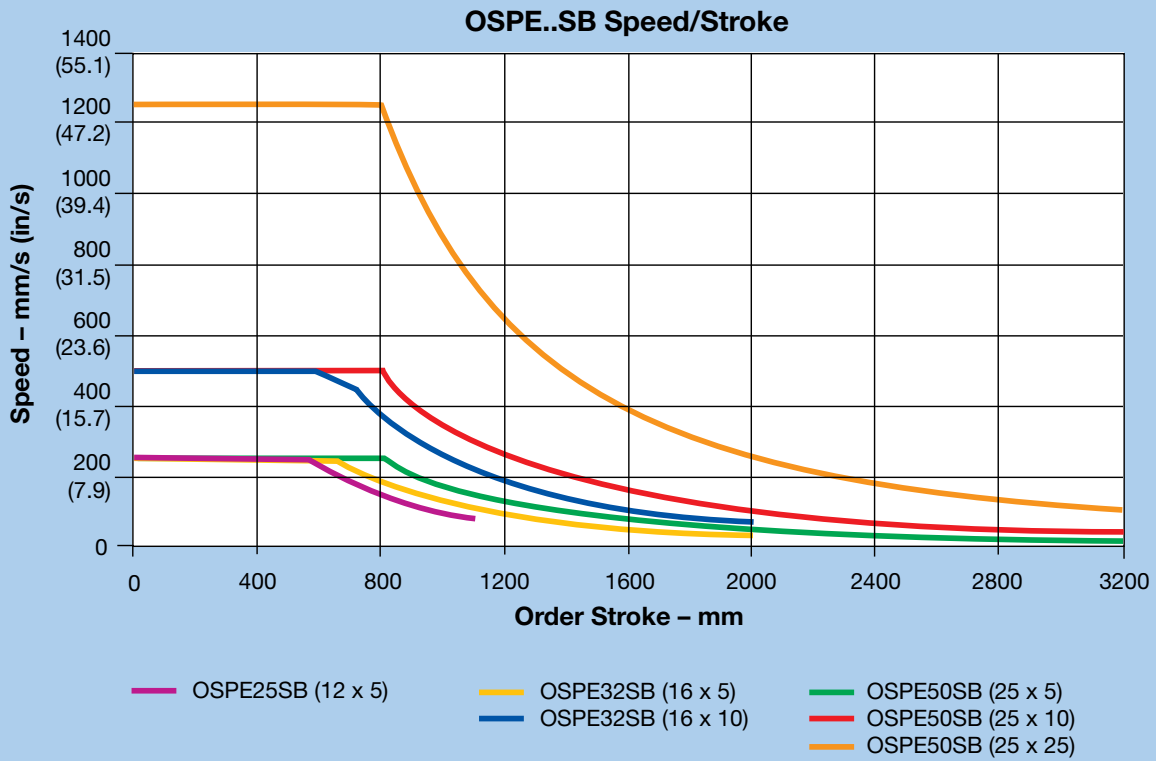

OSPE..SB/ST Screw-Driven Actuators

Base Unit Dimensions w/Standard Carriage — mm

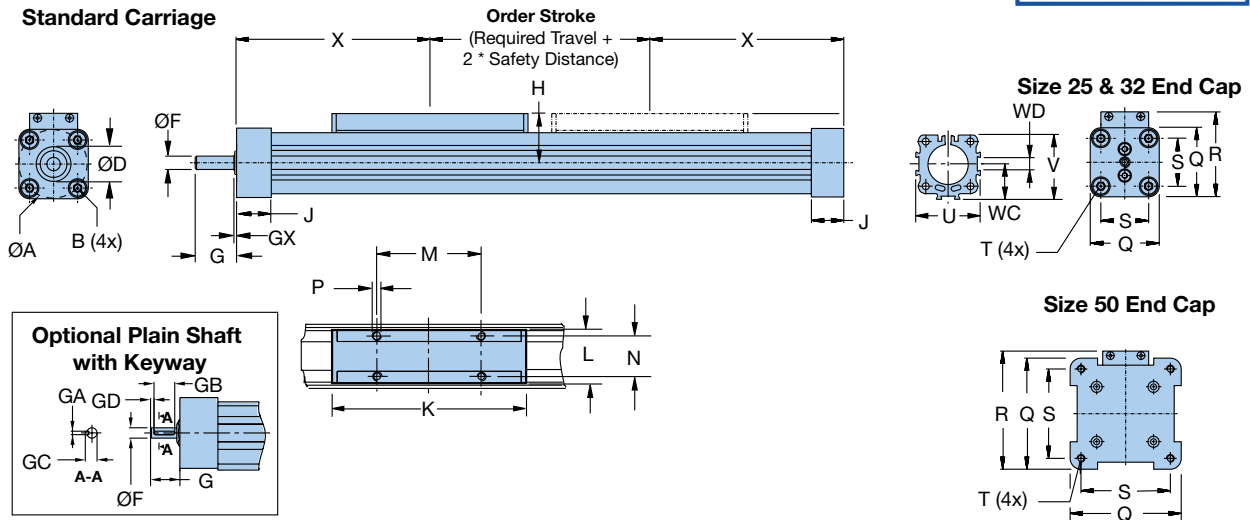

Tandem Carriage (SB models only)

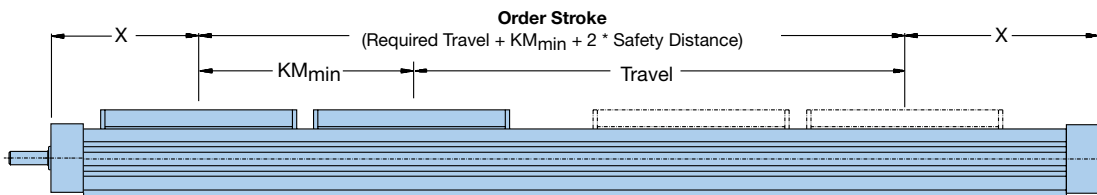

Actuator Size	A	B	D	F	G*	GA	GB	GC	GD	GX	H	J	K
OSPE25SB/ST	38.2	M5 x 10	19 ^{H7}	6 _{h7}	17	2 ^{P9}	12	6.8	2	2	31	22.0	117
OSPE32SB/ST	50.9	M6 x 12	26 ^{H7}	10 _{h7}	31	3 ^{P9}	16	11.2	5	2	38	25.5	152
OSPE50SB/ST	65.0	M6 x 12	40 ^{H7}	15 _{h7}	43	5 ^{P9}	28	17.0	6	3	49	33.0	200

	L	M	N	P	Q	R	S	T	U	V	WC	WD	X
OSPE25SB/ST	33	65	25	M5 x 8	41	52.5	27	M5 x 10	40	39.5	21.5	10.4	100
OSPE32SB/ST	36	90	27	M6 x 10	52	66.5	36	M6 x 12	52	51.7	28.5	10.4	125
OSPE50SB/ST	36	110	27	M6 x 10	87	92.5	70	M6 x 12	76	77.0	43.0	10.4	175

* With optional long drive shaft with keyway, dimension "G" is 24 mm for OSPE25SB/ST; 41 mm for OSPE32SB/ST; 58 mm for OSPE50SB/ST (See ordering information, page 72, order code ④, option "4 -")

Order Stroke Dimensional Requirements

Actuator Size	KM_{min}	KM_{rec}
OSPE25SB/ST	120	190
OSPE32SB/ST	165	230
OSPE50SB/ST	235	320

KM_{min} is the minimum distance between two carriages possible; KM_{rec} is the recommended distance for optimal performance.

* Order Stroke Safety Distance:

The mechanical end position should not be used as a mechanical end stop, thus an additional **Safety Distance** at both ends of travel must be incorporated into the Order Stroke. The safety distance for servo-driven systems is equivalent to the travel distance per revolution of the drive shaft. AC motor-driven systems with VFD require a larger safety distance than servo systems. For further information and design assistance, please consult factory.

PowerSlide Dimensions — mm

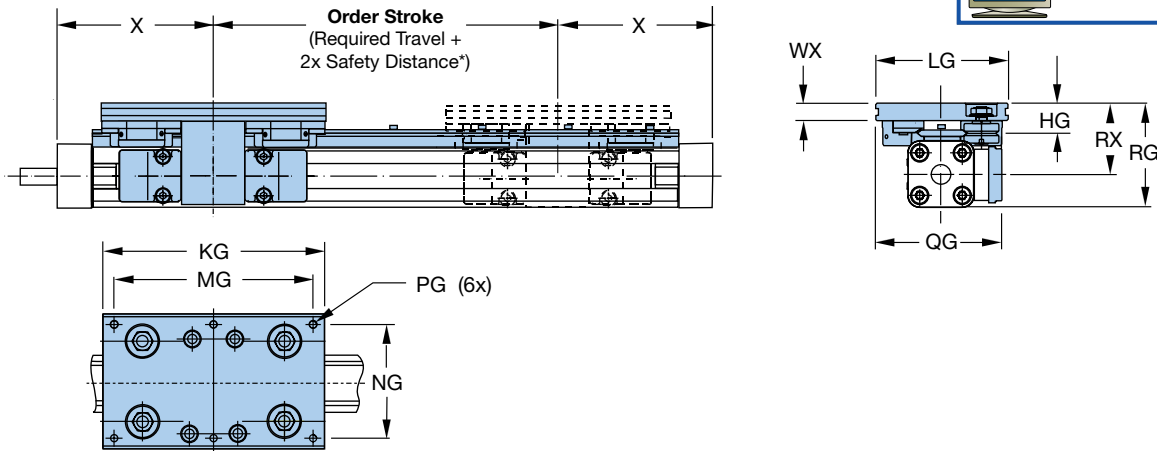

Guide Rail Size	HG	KG	LG	MG	NG	PG	QG	RG	RX	WX	X
PS25/25	20.0	145	80	125	64	M6 x 11	79.5	73.5	53.0	11.0	100
PS 25/35	21.5	156	95	140	80	M6 x 12	89.5	73.0	52.5	12.5	100
PS25/44	26.0	190	116	164	96	M8 x 15	100.0	78.5	58.0	15.0	100
PS32/35	21.5	156	95	140	80	M6 x 12	95.5	84.5	58.5	12.5	125
PS 32/44	26.0	190	116	164	96	M8 x 15	107.0	90.0	64.0	15.0	125
PS50/60	28.5	240	135	216	115	M8 x 17	130.5	123.5	81.0	17.0	175
PS 50/76	39.0	280	185	250	160	M10 x 20	155.5	135.5	93.0	20.0	175

ProLine Dimensions — mm

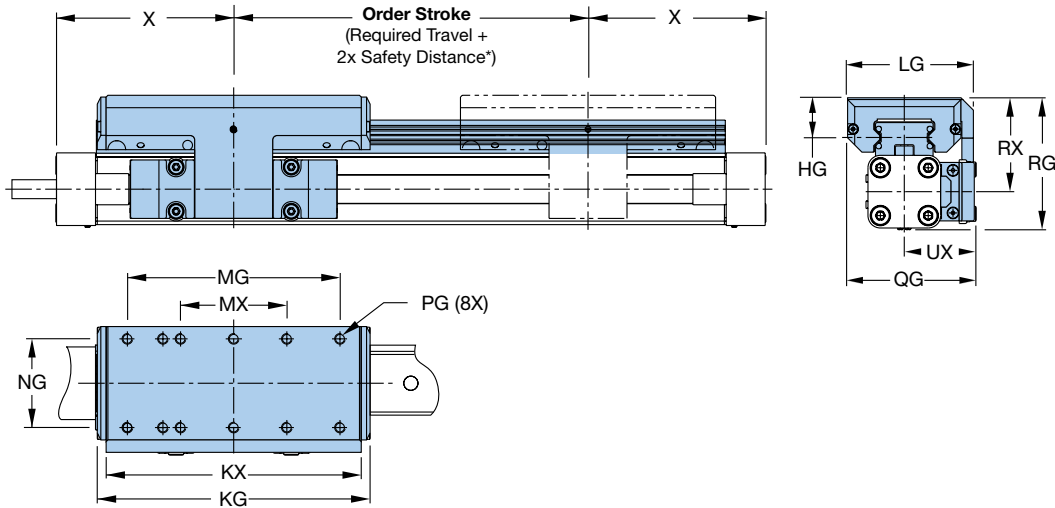

Guide Rail Size	HG	KG	KX	LG	MG	MX	NG	PG	QG	RG	RX	UX	X
PL 25	23	154	144	64	120	60	50	M6 x 12	72.5	74	53	40.5	100
PL 32	25	197	187	84	160	80	64	M6 x 12	91.0	88	62	49.0	125
PL 50	29	276	266	110	240	120	90	M6 x 16	117.0	118	75	62.0	175

OSPE..SB/ST Screw-Driven Actuators

Order Code

R Clevis Mounting Option for Standard Carriage

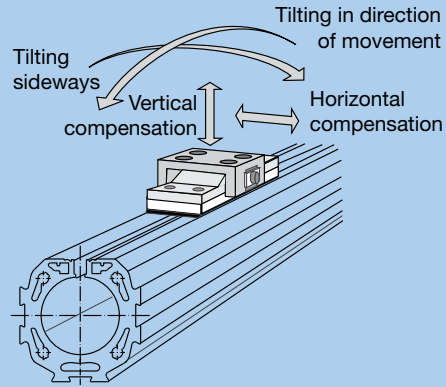
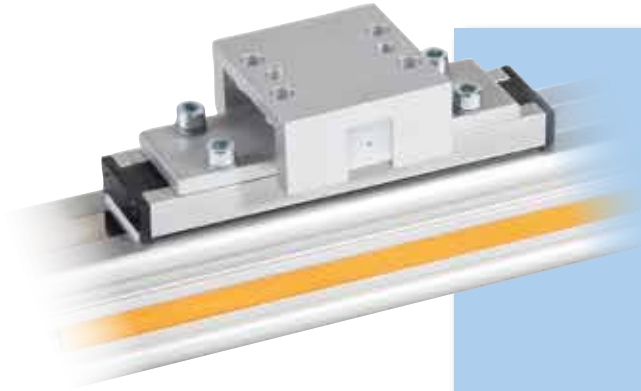

The aluminum clevis mount option bolts directly to the standard carriage to eliminate parallelism deviations and strain to the carriage when the actuator is mounted onto machine guide rails. Clevis mounting provides compensation for misalignment in Z and Y directions and can tilt around the X and Y axis.

When external guides are involved in the application, slight parallelism deviations can lead to mechanical strain on the carriage and actuator. This can be avoided by the use of a clevis mount that provides freedom of movement compensation on several axes.

OSPE25 and OSPE32

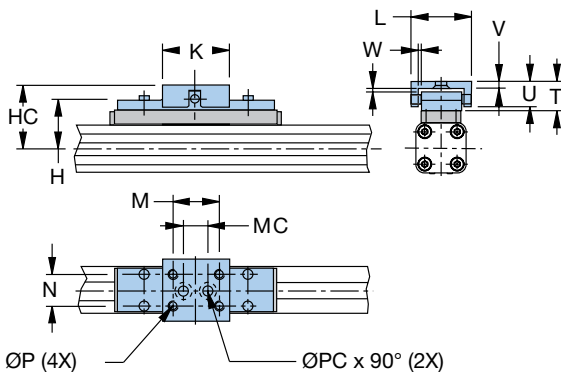

OSPE50

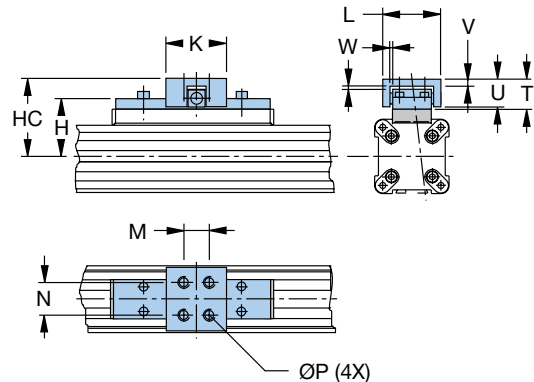

Actuator Size	Part Number	Weight* (kg)	Dimensions – mm												
			H	HC	K	L	M	MC	N	P	PC	T	U	V	W
OSPE25SB/ST	20005FIL	0.091	39	52	40	38	30	16	16	M5	5.5	21	19	3.5	2
OSPE32SB/ST	20096FIL	0.091	50	68	60	62	46	40	25	M6	6.6	30	28	6.0	2
OSPE50SB/ST	20097FIL	0.308	61	79	60	62	46	—	25	M6	—	30	28	6.0	2

*Part number and weight are for individual unit.

M Inversion Mounting Option for Standard Carriage



For dirty environments or space-restricted installations, inversion of the actuator is recommended.

The aluminum inversion bracket transfers the driving force to the opposite side of the actuator

allowing the load to be attached to the top side of the actuator while the carriage and sealing band remain protected on the bottom side. The size and position of the mounting holes are the same as on the standard carriage.

Note: Profile mounts and magnetic switches can only be used on the free side of the actuator.

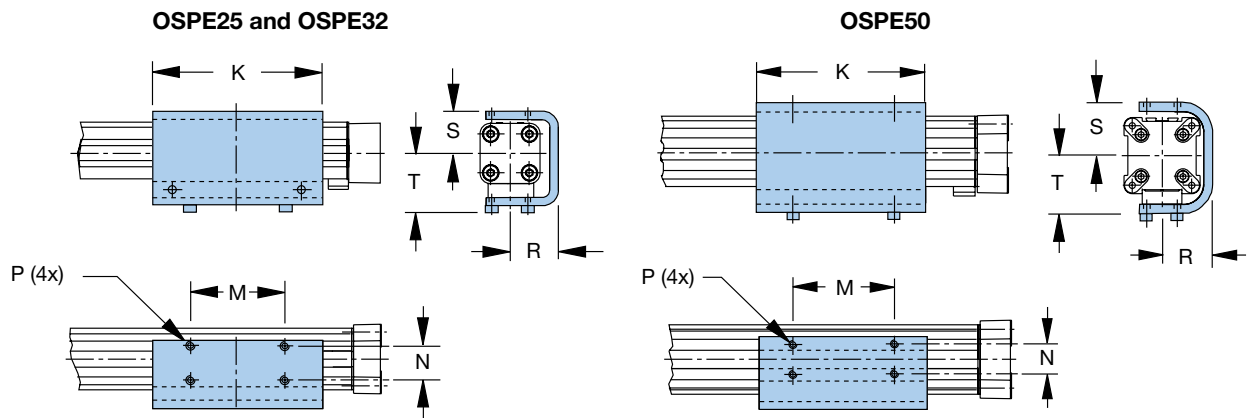

Actuator Size	Part Number	Weight* (kg)	Dimensions — mm						
			K	M	N	P	R	S	T
OSPE25SB/ST	20037FIL	0.302	117	65	25	M5 x 6	33.5	31	31
OSPE32SB/ST	20161FIL	0.449	150	90	27	M6 x 6	39.5	38	38
OSPE50SB/ST	20166FIL	0.947	200	110	27	M6 x 8	52.0	55	55

*Part number and weight are for individual unit.

OSPE..SB/ST Screw-Driven Actuators

Motor Mounting Kit Options

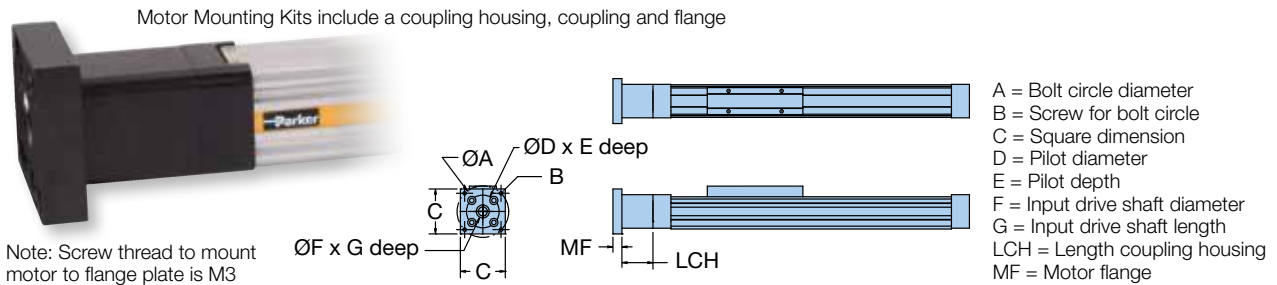

Actuator Size	Order Code ⑥*	Order Code ⑦*	Dimensions — mm								
			A	B	C	D	E	F	G	LCH	MF
OSPE25SB/ST	0	AA **	46.66	M3	41	20.00	1.6	6.35	24.8	38	10
	0	AB	66.67	M5	60	38.10	1.6	6.35	20.5	38	9
	0	AC	66.67	M5	60	38.10	1.6	9.525	20.8	38	9
	0	AD	66.67	M5	60	38.10	1.6	9.525	31.8	38	17
	0	B5 **	46.00	M4	60	30.00	2.5	6.00	25.0	38	10
	0	AM **	46.00	M4 ¹	41	30.00	2.5	8.00	25.0	38	10
	0	B6	63.00	M4	60	40.00	2.5	9.00	20.0	38	9
	0	AH	63.00	M5	60	40.00	2.5	9.00	20.0	38	10
	0	A2	63.00	M5	60	40.00	2.5	11.00	23.0	38	10
	0	B7	70.00	M5	60	50.00	3.0	8.00	25.0	38	15
	0	B8	70.00	M5	60	50.00	3.0	12.00	30.0	38	15
	0	AG	75.00	M5	70	60.00	2.5	11.00	23.0	38	10
OSPE32SB/ST	0	B1	90.00	M5	75	60.00	2.5	11.00	23.0	38	10
	0	AB	66.67	M5	60	38.10	1.6	6.35	20.5	54	10
	0	AC	66.67	M5	60	38.10	1.6	9.525	20.8	54	10
	0	AD	66.67	M5	60	38.10	1.6	9.525	31.8	54	17
	0	BJ	66.67	M5	60	38.10	1.6	12.70	20.0	54	10
	0	AE	98.43	M5	85	73.00	3.0	12.70	30.0	54	15
	0	AF	98.43	M6	85	73.00	3.0	12.70	37.0	54	25
	0	B6 **	63.00	M4	74	40.00	2.5	9.00	20.0	54	10
	0	AH **	63.00	M5	74	40.00	2.5	9.00	20.0	54	10
	0	A2 **	63.00	M5	74	40.00	2.5	11.00	23.0	54	10
	0	B7	70.00	M5	60	50.00	3.0	8.00	25.0	54	15
	0	B8	70.00	M5	60	50.00	3.0	12.00	30.0	54	15
	0	AN	70.00	M5	60	50.00	3.0	14.00	30.0	54	15
	0	AG	75.00	M5	70	60.00	2.5	11.00	23.0	54	10
	0	B9	75.00	M5	70	60.00	2.5	14.00	30.0	54	15
	0	BA	75.00	M5	70	60.00	3.0	16.00	40.0	54	25
	0	B0	75.00	M6	70	60.00	3.0	14.00	30.0	54	15
	0	B1	90.00	M5	75	60.00	2.5	11.00	23.0	54	10
	0	B2	90.00	M5	75	60.00	2.5	14.00	30.0	54	15
	0	BB	90.00	M6	80	70.00	3.0	14.00	30.0	54	15
0	B4	90.00	M6	80	70.00	3.0	16.00	40.0	54	25	
0	B3	95.00	M6	80	50.00	2.5	14.00	30.0	54	15	

* When ordering with actuator, use order code ⑥ (gearhead designation) and order code ⑦ to specify motor mounting kit. See ordering information, page 72.

** Motor mounts with 45° rotated

■ Blue order codes indicate rapid shipment availability

(continued on next page)

(continued from previous page)

Actuator Size	Order Code ⑥ *	Order Code ⑦ *	Dimensions — mm								
			A	B	C	D	E	F	G	LCH	MF
OSPE50SB/ST	0	AE	98.43	M5	88	73.0	3.0	12.70	30.0	75	14
	0	AF	98.43	M6	88	73.0	3.0	12.70	37.0	84	15
	0	B9	75.00	M5	85	60.0	2.5	14.00	30.0	75	14
	0	BA **	75.00	M5	86	60.0	3.0	16.00	40.0	84	15
	0	B0	75.00	M6	88	60.0	3.0	14.00	30.0	75	14
	0	B2	90.00	M5	80	60.0	2.5	14.00	30.0	75	14
	0	BB	90.00	M6	80	70.0	3.0	14.00	30.0	75	14
	0	B4	90.00	M6	86	70.0	3.0	16.00	40.0	84	15
	0	AP	90.00	M6	86	70.0	3.0	19.00	40.0	84	15
	0	B3	95.00	M6	85	50.0	2.5	14.00	30.0	75	14
	0	A1	99.00	M6	88	73.0	3.0	9.525	31.5	75	14
	0	A3	100.00	M6	88	80.0	3.5	14.00	30.0	75	14
	0	AL	100.00	M6	88	80.0	3.0	16.00	40.0	84	15
	0	AJ	100.00	M6	88	80.0	3.0	19.00	40.0	84	15
	0	A4	115.00	M8	100	95.0	3.5	19.00	40.0	84	15
	0	BD	130.00	M8	115	95.0	3.0	19.00	40.0	84	15
	0	BF	130.00	M8	115	110.0	3.5	19.00	40.0	84	15

* When ordering with actuator, use order code ⑥ (gearhead designation) and order code ⑦ to specify motor mounting kit. See ordering information, page 72.

** Motor mounts with 45° rotated

■ Blue order codes indicate rapid shipment availability

OSPE..SB/ST Screw-Driven Actuators

Mounted Motor Options

Mounted Motor Options include a coupling housing, coupling, flange and motor

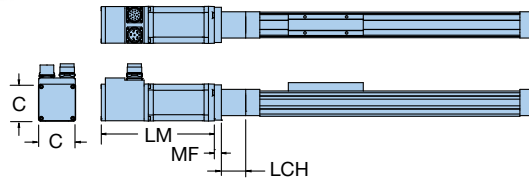

C = Square dimension
LCH = Length coupling housing
LM = Length motor
MF = Motor flange

Actuator Size	Order Code ⑥ *	Order Code ⑦ *	Motor description	Dimensions — mm			
				C	LCH	LM	MF
OSPE25SB/ST	0	L0	LV233-01-10	58	38	79	9
	0	L1	HV233-01-10	58	38	79	9
	0	KA	MPE0402A4E-KC1N	40	38	91	10
	0	K0	BE233FJ-KPSN	58	38	143	17
	0	K1	BE233FJ-KPSN with brake (CM233FJ-115027)	58	38	178	17
OSPE32SB/ST	0	L0	LV233-01-10	58	54	79	10
	0	L1	HV233-01-10	58	54	79	10
	0	L2	LV343-01-10	86	54	127	25
	0	L3	HV343-01-10	86	54	127	25
	0	KC	MPE0602A4E-KC1N	60	54	118	15
	0	K0	BE233FJ-KPSN	58	54	143	18
	0	K1	BE233FJ-KPSN with brake (CM233FJ-115027)	58	54	178	18
	0	K2	BE344LJ-KPSN	86	54	188	16
OSPE50SB/ST	0	L2	LV343-01-10	86	84	127	15
	0	L3	HV343-01-10	86	84	127	15
	0	KG	MPE0804A4E-KC1N	80	84	146	15
	0	K2	BE344LJ-KPSN	86	75	188	14
	0	K3	BE344LJ-KPSB	86	75	220	14
	0	M0	MPP0923D1E-KPSN	89	84	178	15
	0	M1	MPP0923D1E-KPSB	89	84	212	15
	0	M2	MPP1003D1E-KPSN	98	84	175	15
	0	M3	MPP1003D1E-KPSB	98	84	224	15
	0	M4	MPP1003R1E-KPSN	98	84	175	15
0	M5	MPP1003R1E-KPSB	98	84	224	15	

*When ordering with actuator, use order code ⑥ (gearhead designation) and order code ⑦ to specify mounted motor. See ordering information, page 72.

■ Blue order codes indicate rapid shipment availability

Gearhead Mounting Kit Options

Gearhead Mounting Kits include a coupling housing, coupling and flange

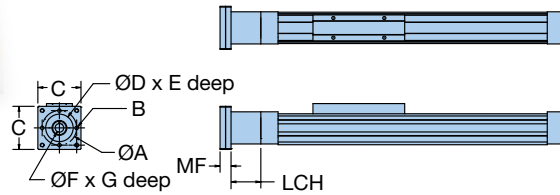

A = Bolt circle diameter
 B = Screw for bolt circle
 C = Square dimension
 D = Pilot diameter
 E = Pilot depth
 F = Input drive shaft diameter
 G = Input drive shaft length
 LCH = Length coupling housing
 MF = Motor flange

Actuator Size	Order Code ⑥*	Order Code ⑦*	Dimensions — mm								
			A	B	C	D	E	F	G	LCH	MF
OSPE25SB/ST	0	C0	44	S4	54	35	3	12	25	38	14.0
OSPE32SB/ST	0	C0	44	S4	60	35	3	12	25	54	13.0
	0	C1	62	S5	75	52	8	16	36	54	20.0
OSPE50SB/ST	0	C1	62	S5	75	52	8	16	36	84	16.3
	0	C2	80	S6	95	68	10	22	46	84	23.0

*When ordering with actuator, use order code ⑥ (gearhead designation) and order code ⑦ to specify gearhead mounting kit See ordering information, page 72.

■ Blue order codes indicate rapid shipment availability

OSPE..SB/ST Screw-Driven Actuators

Mounted Gearhead with Motor Mounting Kit Options



Mounted Gearhead with Motor Mounting Kit include a coupling housing, coupling, flange, and gearhead with coupler and flange

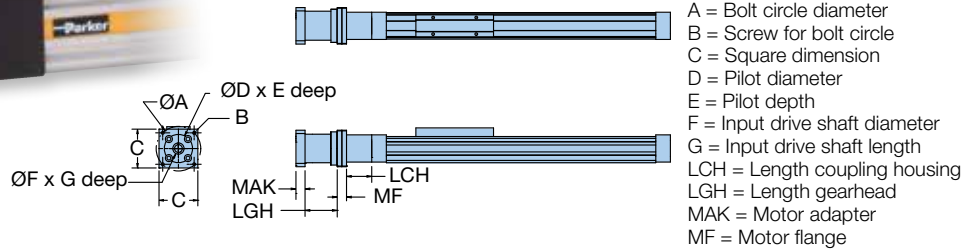

Actuator Size	Order Code ⑥ ¹	Order Code ⑦ ²	Dimensions – mm										
			A	B	C	D	E	F	G	LCH	LGH	MAK	MF
OSPE25SB/ST	A or B	AA	46.66	M3	43	20.00	1.6	6.35	24.8	38	48.5	19.0	14.0
	A or B	AB	66.67	M5	55	38.10	1.6	6.35	20.5	38	48.5	15.7	14.0
	A or B	B5	46.00	M4	43	30.00	2.5	6.00	25.0	38	48.5	19.0	14.0
	A or B	AM	46.00	M4	43	30.00	2.5	8.00	25.0	38	48.5	19.0	14.0
	A or B	B6	63.00	M4	55	40.00	2.5	9.00	20.0	38	48.5	13.7	14.0
A or B	AH	63.00	M5	55	40.00	2.5	9.00	20.0	38	48.5	19.0	14.0	
OSPE32SB/ST	C, D or E	AB	66.67	M5	62	38.10	1.6	6.35	20.5	54	67.0	16.5	20.0
	C, D or E	AC	66.67	M5	62	38.00	1.6	9.525	20.8	54	67.0	16.5	20.0
	C, D or E	AD	66.67	M5	62	38.10	1.6	9.525	31.8	54	67.0	22.5	20.0
	C, D or E	AE	98.43	M5	80	73.03	3.0	12.70	30.0	54	67.0	22.5	20.0
	C, D or E	AF	98.43	M6	85	73.03	3.0	12.70	37.0	54	67.0	30.0	20.0
	C, D or E	B6	63.00	M4	62	40.00	2.5	9.00	20.0	54	67.0	16.5	20.0
	C, D or E	AH	63.00	M5	62	40.00	2.5	9.00	20.0	54	67.0	16.5	20.0
	C, D or E	B8	70.00	M5	62	50.00	3.0	12.00	30.0	54	67.0	22.5	20.0
	C, D or E	AN	70.00	M5	62	50.00	3.0	14.00	30.0	54	67.0	22.5	20.0
	C, D or E	AG	75.00	M5	62	60.00	2.5	11.00	23.0	54	67.0	16.5	20.0
	C, D or E	B9	75.00	M5	62	60.00	2.5	14.00	30.0	54	67.0	22.5	20.0
	C, D or E	BB	90.00	M6	80	70.00	3.0	14.00	30.0	54	67.0	22.5	20.0
	C, D or E	A3	100.00	M6	89	80.00	3.5	14.00	30.0	54	67.0	22.5	20.0
OSPE50SB/ST	C, D or E	AB	66.67	M5	62	38.10	1.6	6.35	20.5	84	67.0	16.5	16.3
	C, D or E	AC	66.67	M5	62	38.00	1.6	9.525	20.8	84	67.0	16.5	16.3
	C, D or E	AD	66.67	M5	62	38.10	1.6	9.525	31.8	84	67.0	22.5	16.3
	C, D or E	AE	98.43	M5	80	73.03	3.0	12.70	30.0	84	67.0	22.5	16.3
	C, D or E	AF	98.43	M6	85	73.03	3.0	12.70	37.0	84	67.0	30.0	16.3
	C, D or E	B6	63.00	M4	62	40.00	2.5	9.00	20.0	84	67.0	16.5	16.3
	C, D or E	AH	63.00	M5	62	40.00	2.5	9.00	20.0	84	67.0	16.5	16.3
	C, D or E	B8	70.00	M5	62	50.00	3.0	12.00	30.0	84	67.0	22.5	16.3
	C, D or E	AN	70.00	M5	62	50.00	3.0	14.00	30.0	84	67.0	22.5	16.3
	C, D or E	AG	75.00	M5	62	60.00	2.5	11.00	23.0	84	67.0	16.5	16.3
	C, D or E	B9	75.00	M5	62	60.00	2.5	14.00	30.0	84	67.0	22.5	16.3
	C, D or E	BB	90.00	M6	80	70.00	3.0	14.00	30.0	84	67.0	22.5	16.3
	C, D or E	A3	100.00	M6	89	80.00	3.5	14.00	30.0	84	67.0	22.5	16.3

¹ When ordering with actuator, use order code ⑥ to specify mounted gearhead size and ratio: **A** PV40TA-005 (ratio 5:1); **B** PV40TA-010 (ratio 10:1); **C** PV60TA-003 (ratio 3:1); **D** PV60TA-005 (ratio 5:1); **E** PV60TA-010 (ratio 10:1). See ordering information, page 72.

² When ordering with actuator, use order code ⑦ to specify motor mounting kit. See ordering information, page 72.

■ Blue order codes indicate rapid shipment availability

Mounted Gearhead and Motor Options

Mounted Gearhead and Mounted Motor Options include a coupling housing, coupling, flange, gearhead with coupler, flange and motor

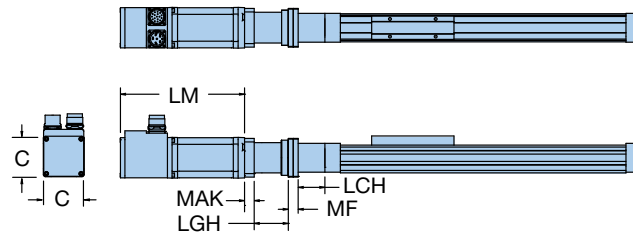

C = Square dimension
LCH = Length coupling housing
LGH = Length gearhead
LM = Length motor
MAK = Motor adapter
MF = Motor flange

Actuator Size	Order Code ⑥ ¹	Order Code ⑦ ²	Motor description	Dimensions — mm					
				C	LCH	LGH	LM	MAK	MF
OSPE25SB/ST	A or B	L0	LV233-01-10	58	38	48.5	79	15.7	14.0
	A or B	L1	HV233-01-10	58	38	48.5	79	15.7	14.0
	A or B	KA	MPE0402A4E-KC1N	40	38	48.5	91	19.0	14.0
OSPE32SB/ST	C, D or E	L0	LV233-01-10	58	54	67.0	79	16.5	20.0
	C, D or E	L1	HV233-01-10	58	54	67.0	79	16.5	20.0
	C, D or E	L2	LV343-01-10	86	54	67.0	127	30.0	20.0
	C, D or E	L3	HV343-01-10	86	54	67.0	127	30.0	20.0
	C, D or E	KC	MPE0602A4E-KC1N	60	54	67.0	118	22.5	20.0
	C, D or E	K0	BE233FJ-KPSN	58	54	67.0	143	22.5	20.0
	C, D or E	K1	BE233FJ-KPSN with brake (CM233FJ-115027)	58	54	67.0	178	22.5	20.0
	C, D or E	K2	BE344LJ-KPSN	86	54	67.0	188	22.5	20.0
	C, D or E	K3	BE344LJ-KPSB	86	54	67.0	220	22.5	20.0
OSPE50SB/ST	C, D or E	L0	LV233-01-10	58	84	67.0	79	16.5	16.3
	C, D or E	L1	HV233-01-10	58	84	67.0	79	16.5	16.3
	C, D or E	L2	LV343-01-10	86	84	67.0	127	30.0	16.3
	C, D or E	L3	HV343-01-10	86	84	67.0	127	30.0	16.3
	C, D or E	KC	MPE0602A4E-KC1N	60	84	67.0	118	22.5	16.3
	C, D or E	K0	BE233FJ-KPSN	58	84	67.0	143	22.5	16.3
	C, D or E	K1	BE233FJ-KPSN with brake (CM233FJ-115027)	58	84	67.0	178	22.5	16.3
	C, D or E	K2	BE344LJ-KPSN	86	84	67.0	188	22.5	16.3
	C, D or E	K3	BE344LJ-KPSB	86	84	67.0	220	22.5	16.3

¹ When ordering with actuator, use order code ⑥ to specify mounted gearhead size and ratio: **A** PV40TA-005 (ratio 5:1); **B** PV40TA-010 (ratio 10:1); **C** PV60TA-003 (ratio 3:1); **D** PV60TA-005 (ratio 5:1); **E** PV60TA-010 (ratio 10:1). See ordering information, page 72.

² When ordering with actuator, use order code ⑦ to specify mounted motor on gearhead. See ordering information, page 72.



■ Blue order codes indicate rapid shipment availability

OSPE..SB/ST Screw-Driven Actuators

End Cap Mounting Options

See "Maximum Permissible Unsupported Length" (page 70), for end cap and profile mounting placement requirements.

End Cap Mounting Selection Overview

Type	Standard Carriage			PowerSlide						ProLine			
	25	32	50	25/25	25/35	25/44	32/35	32/44	50/60	50/76	25	32	50
Standard 	A1	•	•										
	A2										•	•	
	A3				•	•		•					
Reinforced 	B1	•	•	•	•	•	•	•			•	•	
	B4								•	•			
Block 	C1			•						•			•
	C2												•
	C3								•				
	C4									•			

• Recommended for mounting position with carriage on top • Recommended for mounting position carriage side only (3 or 9 o'clock position)

Order Code

1, 2 or 3
(1 pair)

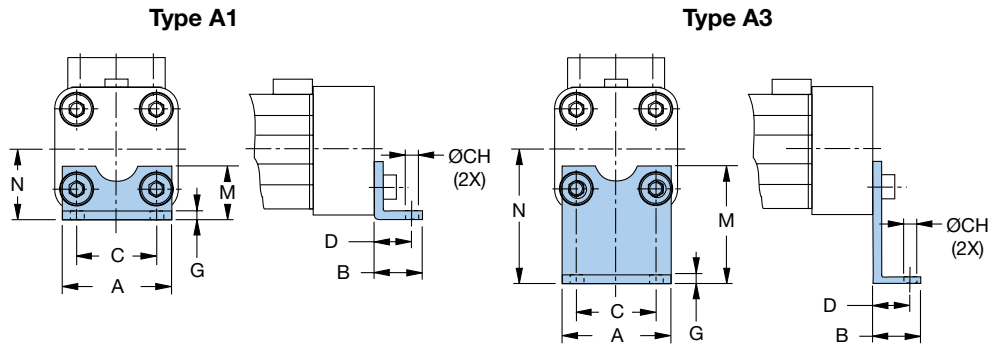

Type A1, A2 and A3 – Standard End Cap

Actuator Size	Type	Part Number*	Weight* (kg)	Dimensions — mm								
				A	B	C	CH	D	G	M	N	
OSPE25SB/ST	A1	18156FIL	0.031								18	22
	A2	18157FIL	0.044	39	22	27	5.8	16	2.5		33	37
	A3	18158FIL	0.055								45	49
OSPE32SB/ST	A1	18161FIL	0.050								20	30
	A2	18162FIL	0.066	50	26	36	6.6	18	3.0		34	44
	A3	18163FIL	0.159								42	52

*Part number and weight are for individual unit.

Order
Code

4 or 5
(1 pair)

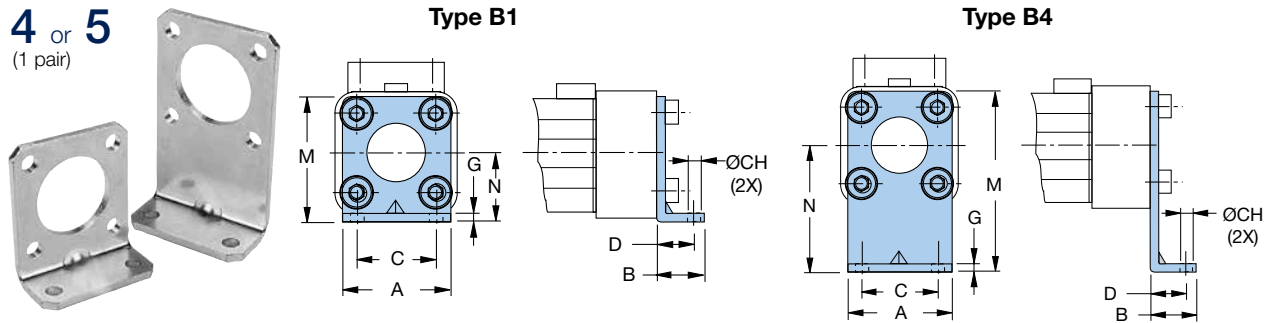

Type B1 and B4 – Reinforced End Cap

Actuator Size	Type	Part Number*	Weight* (kg)	Dimensions – mm							
				A	B	C	CH	D	G	M	N
OSPE25SB/ST	B1	18159FIL	0.010	39	22	27	5.8	16	2.5	42	22
	B4	18160FIL	0.110							80	60
OSPE32SB/ST	B1	18164FIL	0.078	50	26	36	6.6	18	3.0	55	30
	B4	18165FIL	0.380							85	60

*Part number and weight are for individual unit.

Order
Code

1, 2, 3 or 4
(1 pair)

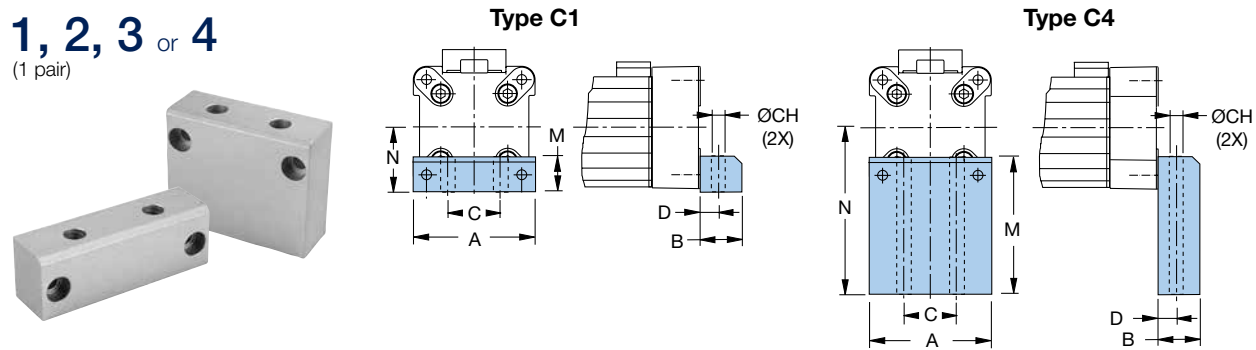

Type C1, C2, C3 and C4 – Block End Cap

Actuator Size	Type	Part Number*	Weight* (kg)	Dimensions – mm							
				A	B	C	CH	D	M	N	
OSPE50SB/ST	C1	18166FIL	0.146							30	48
	C2	18167FIL	0.210							39	57
	C3	18168FIL	0.300	86	24	40	9.0	12.5		54	72
	C4	18169FIL	0.412							77	95



*Part number and weight are for individual unit.

OSPE..SB/ST Screw-Driven Actuators

Profile Mounting Options

See "Maximum Permissible Unsupported Length" (page 70), for end cap and profile mounting placement requirements.

Profile Mounting Selection Overview

Type	Standard Carriage			PowerSlide								ProLine		
	25	32	50	25/25	25/35	25/44	32/35	32/44	50/60	50/76	25	32	50	
 2 Internal Threads D1														
 2 Thru Holes E1 E2 E3 E4														
 3 Thru Holes MAE														

• Recommended for mounting position with carriage on top • Recommended for mounting position carriage side only (3 or 9 o'clock position)

Order Code

2, 5 or 8
(1, 2 or 3 pair)

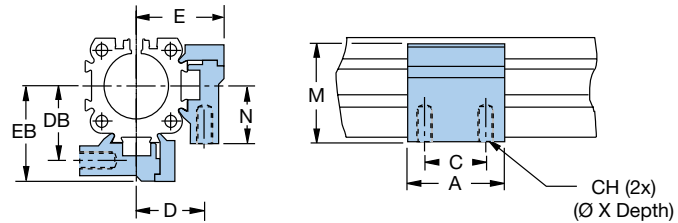

Type D1 (with two internal threads)

Actuator Size	Part Number*	Weight* (kg)	Dimensions — mm								
			A	C	CH	D	DB	E	EB	M	N
OSPE25SB/ST	20008FIL	0.061	50	36	M5 x 10	27	28.5	34.5	36	38	22
OSPE32SB/ST	20157FIL	0.072	50	36	M5 x 10	33	35.5	40.5	43	46	30
OSPE50SB/ST	20162FIL	0.167	60	45	M6 x 11	40	45.0	52.0	57	71	48

*Part number and weight are for individual unit.

Order Code

E1 **1, 4** or **7** (1, 2 or 3 pair) E3 **L, P** or **S** (1, 2 or 3 pair)
 E2 **K, N** or **R** (1, 2 or 3 pair) E4 **M, Q** or **T** (1, 2 or 3 pair)

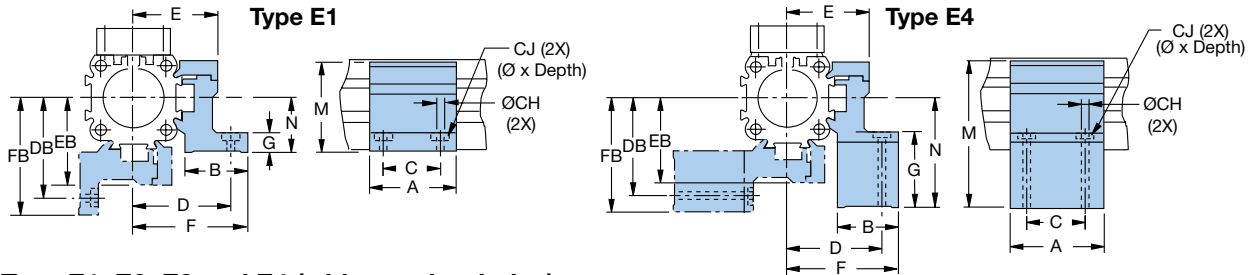

Type E1, E2, E3 and E4 (with two thru holes)

Actuator Size	Part Number*	Part Weight* (kg)	Dimensions — mm														
			A	B	C	CH	CJ	D	DB	E	EB	F	FB	G	M	N	
OSPE25SB/ST	E1 20009FIL	0.074													8	38	22
	E2 20352FIL	0.125	50	26	36	5.5	10 x 5.7	40	41.5	34.5	36	47.5	49	23	53	37	
	E3 20353FIL	0.120												35	65	49	
	E4 20354FIL	0.020												46	76	60	
OSPE32SB/ST	E1 20158FIL	0.092												10	46	30	
	E2 20355FIL	0.141	50	27	36	5.5	10 x 5.7	46	48.5	40.5	43	54.5	57	24	60	44	
	E3 20356FIL	0.140												32	68	52	
	E4 20357FIL	0.197												40	76	60	
OSPE50SB/ST	E1 20163FIL	0.189												10	71	48	
	E2 20361FIL	0.235	60	34	45	7.0	—	59	64.0	52.0	57	67.0	72	19	80	57	
	E3 20362FIL	0.338												31	95	72	
	E4 20363FIL	0.442												57	118	95	

*Part number and weight are for individual unit.

Order Code

3, 6 or **9**
(1, 2 or 3 pair)

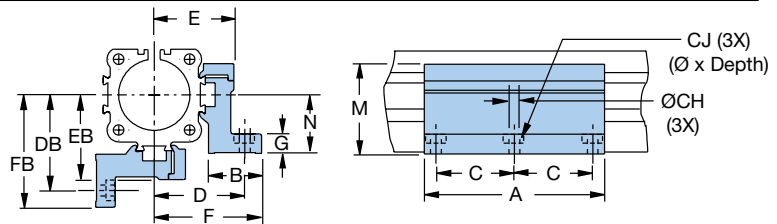

Type MAE (with three thru holes)

Actuator Size	Part Number*	Part Weight* (kg)	Dimensions — mm													
			A	B	C	CH	CJ	D	DB	E	EB	F	FB	G	M	N
OSPE25SB/ST	12278FIL	0.271	92	26	40	5.5	10 x 5.7	40	41.5	34.5	36	47.5	49	8	38	22
OSPE32SB/ST	12279FIL	0.334	92	27	40	5.5	10 x 5.7	46	48.5	40.5	43	54.5	57	10	46	30
OSPE50SB/ST	12280FIL	0.668	112	34	45	7.0	—	59	64.0	52.0	57	67.0	72	10	71	48

*Part number and weight are for individual unit.

OSPE..SB/ST Screw-Driven Actuators

Maximum Permissible Unsupported Length — Determining end cap and profile mounting placement

OSPE..SB/ST Series actuators need to be mounted onto a solid machine base or frame structure using appropriately positioned end cap and profile mounts. This ensures that the actuator will not undergo excessive deflection based on the application's load and length requirements.

The greater the load and/or the longer the unsupported length between mounts, the more the actuator is susceptible to deflection. Loading is also dependent on the carriage orientation (F_z for top oriented carriage or F_y for a side mounted carriage).

Standard Carriage, Tandem Carriage, PowerSlide or ProLine

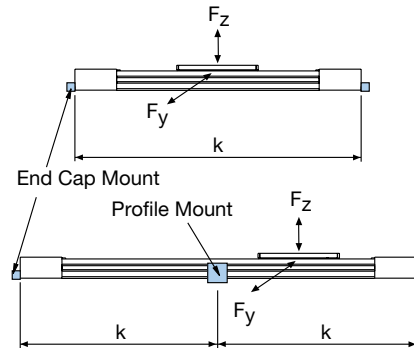

To determine correct end cap and profile mount placement, please follow the steps shown in the example below.

Use the deflection graphs (page 71), to ensure that the load will not exceed the maximum allowed deflection.

Example:

A horizontal application uses an OSPE32B with a top oriented carriage. The maximum load to the carriage is 80 kg and the order stroke is 1,550 mm (see page 56 to calculate order stroke).

Therefore, the overall length of the actuator will be 1,800 mm:

$$1,550 \text{ mm} + 2 \times \text{Dim "X"} (125 \text{ mm}) = 1,800 \text{ mm}$$

- 1) Use the appropriate F_z graph (page 71) for a top loaded carriage. (Note: with the standard carriage, top loaded F_z and side loaded F_y values are the same).
- 2) Calculate the Load "F" in Newtons based on the 80 kg application load requirement:

$$80 \text{ kg} \times 9.81 \text{ kg/ms}^2 = 784.8 \text{ N}$$

- 3) Draw a line from 785 N on the Y-axis to the OSPE32B curve, then down to the X-axis.
- 4) The value of "k" is approximately 1,600 mm.
- 5) Since the overall length (1,800 mm) is greater than this value "k", the actuator will require an additional third fixture point — one end cap mount and two profile mounts — equally spaced to create a distance "k" of 800 mm in between.
- 6) Maximum deflection of the actuator with this mounting configuration will be less than 1.6 mm:

$$0.2\% \text{ of } 800 \text{ mm} = 1.6 \text{ mm}$$

Standard Carriage Load-Distance

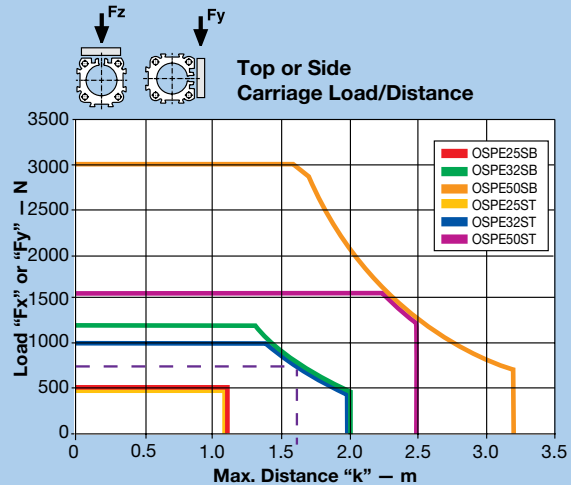

To further reduce deflection:

If the application requires less deflection, then simply reduce the distance "k" appropriately. In this example, for instance, the application must not exceed 1 mm (1/2 the maximum deflection calculated). Therefore, "k" must also be 1/2, or 400 mm.

To achieve this reduced maximum deflection, the actuator will require five fixture points — one end cap mount and four profile mounts — equally spaced with a distance "k" of 400 mm in between.

Standard Carriage Load-Distance

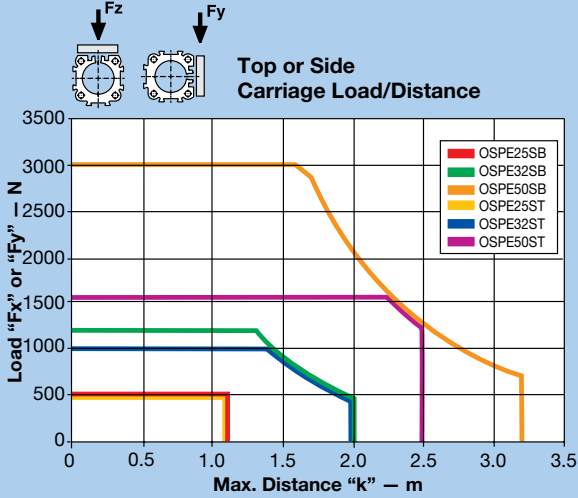

Maximum Permissible Unsupported Length

Determining end cap and profile mounting placement

Use the appropriate deflection graph to ensure that the application load does not exceed the deflection curve. Supporting the actuator within the recommended maximum distance "k" will ensure that the installation will have a maximum deflection equal to 0.2% of distance "k."

To further reduce deflection, simply reduce the distance between end cap and profile mounts as described in the example on the previous page.

PowerSlide Carriage Load-Distance

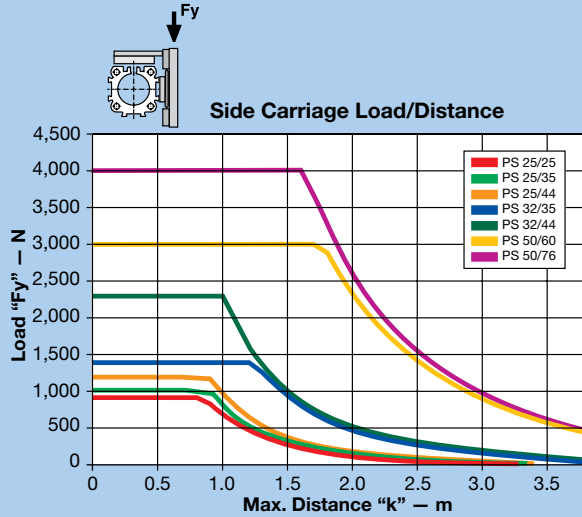
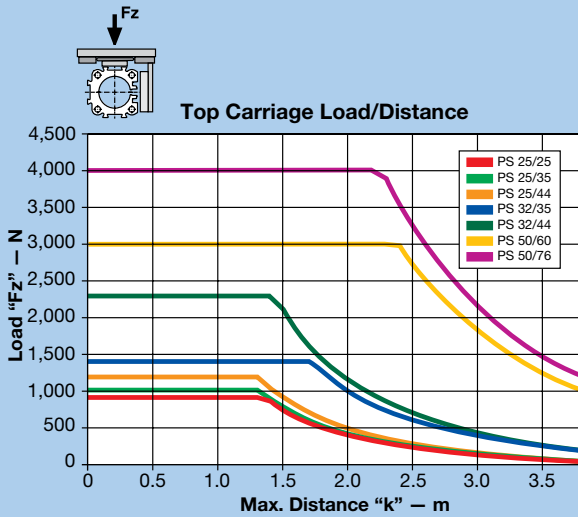

ProLine Carriage Load-Distance

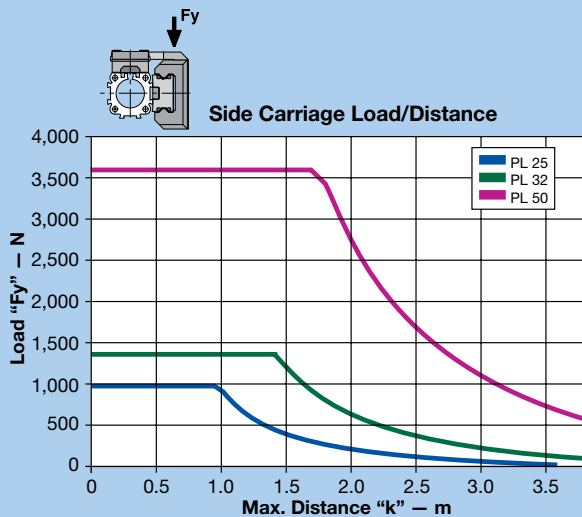
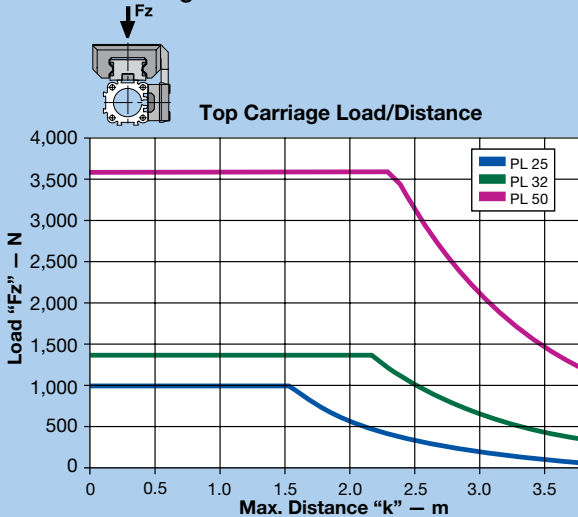

OSPE..SB/ST Screw-Driven Actuators

Ordering Information

Select an order code from each of the numbered fields to create a complete OSPE..SB or ST model order number. Include hyphens and non-selective characters as shown in example below.

① ② ③ ④ ⑤ ⑥ ⑦ ⑧ ⑨ ⑩ ⑪ ⑫ ⑬ ⑭

Order Number Example: OSPE 25 - 1 0 0 0 0 - 00000 - P 0 0 0 0 0

① Series

OSPE Origa System Plus Electromechanical

② Actuator Bore Size

25 41 mm W x 53 mm H
32 52 mm W x 67 mm H
50 87 mm W x 93 mm H

③ Drive Train

1 SB – Ball screw actuator with internal glider bearing
2 ST – Trapezoidal screw actuator with internal glider bearing

④ Carriage

0 Standard
1 Tandem (two carriages for higher load capabilities (OSPE..SB models only))

⑤ Screw Lead

OSPE..SB	Bore Size	25	32	50
3 5 mm		•	•	•
4 10 mm			•	•
5 25 mm				•
OSPE..ST	Bore Size	25	32	50
4 4 mm		•	•	
6 6 mm				•

⑥ Mounted Gearhead Options

0 No gearhead
A PV40TA-005 (gear ratio 5:1)*
B PV40TA-010 (gear ratio 10:1)*
C PV60TA-003 (gear ratio 3:1)*
D PV60TA-005 (gear ratio 5:1)*
E PV60TA-010 (gear ratio 10:1)*

* Requires selection from "Mounted Gearhead with Motor Mounting Kit" (see page 64), or "Mounted Gearhead and Motor" (see page 65) for item ⑦ below.

⑦ Drive Shaft and Gearhead/Motor Mounting Options

0 - Plain drive shaft
3 - Drive shaft with keyway
4 - Long drive shaft with keyway
 Motor Mounting Kits* (see page 60 for available option dimensions and delivery)
 Mounted Motors* (see page 62 for available option dimensions and delivery)
 Gearhead Mounting Kits* (see page 63 for available option dimensions and delivery)
 Mounted Gearhead with Motor Mounting Kits* (see page 64 for available option dimensions and delivery)
 Mounted Gearhead and Motor (see page 65 for available option dimensions and delivery)

* All gearhead and motor mounting options are equipped with a plain drive shaft (no keyway options)

⑧ Order Stroke*

00000 5-digit input (in mm)

* See page 56 to calculate required order stroke.

Maximum catalog stroke:

OSPE25SB/ST = 01100 mm;

OSPE32SB/ST = 02000 mm;

OSPE50SB/ST = 02000 mm

Longer strokes available upon request. Consult factory.

⑨ Hardware and Dovetail Groove Covers

P Standard hardware with Parker gold cover strip

■ Blue order codes indicate rapid shipment availability

⑩ Carriage Options

0	No external guide rail
6	ProLine PL25, PL32, PL50*
E	PowerSlide PS25/25*
F	PowerSlide PS25/35 or PS32/35*
G	PowerSlide PS25/44 or PS32/44*
H	PowerSlide PS50/60*
I	PowerSlide PS50/76*
M	Inversion Mounting**
R	Clevis Mounting **

* Requires standard carriage (select order code "0" from ④). See page 57 for dimensions and additional information.

** Requires standard carriage (select order code "0" from ④). See page 58 for Clevis Mounting and page 59 for Inversion Mounting.

⑪ External Guide Rail Orientation

0  Guide Rail (right)

1  Guide Rail (left)

⑫ End Cap Mounting (see page 66)

0	No end cap mounting
1	1 piece A1* (standard end cap) or C1** (block end cap)
2	1 piece A2* (standard end cap) or C2** (block end cap)
3	1 piece A3* (standard end cap) or C3** (block end cap)
4	1 piece B1* (reinforced end cap) or C4** (block end cap)
5	1 piece B4* (reinforced end cap)

* For size 25 and 32

** For size 50

⑬ Profile Mounting (see page 68)

0	No profile mounting
2	1 pair D1 (with 2 internal threads)
5	2 pair D1 (with 2 internal threads)
8	3 pair D1 (with 2 internal threads)
1	1 pair E1 (with 2 thru holes)
4	2 pair E1 (with 2 thru holes)
7	3 pair E1 (with 2 thru holes)
3	1 pair MAE (with 3 thru holes)
6	2 pair MAE (with 3 thru holes)
9	3 pair MAE (with 3 thru holes)
K	1 pair E2 (with 2 thru holes)
N	2 pair E2 (with 2 thru holes)
R	3 pair E2 (with 2 thru holes)
L	1 pair E3 (with 2 thru holes)
P	2 pair E3 (with 2 thru holes)
S	3 pair E3 (with 2 thru holes)
M	1 pair E4 (with 2 thru holes)
Q	2 pair E4 (with 2 thru holes)
T	3 pair E4 (with 2 thru holes)

⑭ Magnetic Sensor Mounting*

0	No sensor mounting
A	1 pc. N.O., NPN, with M8 connector
B	2 pc. N.C., NPN, with M8 connector
C	1 pc. N.O., NPN, with M8 connector 2 pc. N.C., NPN, with M8 connector
D	1 pc. N.O., PNP, with M8 connector
E	2 pc. N.C., PNP, with M8 connector
F	1 pc. N.O., PNP, with M8 connector 2 pc. N.C., PNP, with M8 connector

* Extension cable with M8 plug and 5 m cable flying lead cable for Sensor with M8 connector can be ordered separately; use part number 003-2918-01

■ Blue order codes indicate rapid shipment availability

OSPE..BV Fixed Belt-Driven Actuators

Actuators with Fixed Belt for Vertical Applications

The OSPE..BV vertical fixed belt-driven actuator with integrated ball bearing guide is designed specifically for lifting loads in vertical orientation. The light weight design allows to use smaller motors with this actuator keeping the robust and aesthetically pleasing design of the OSPE series.

The compact and modular design allows the integration of the OSPE..BV in any machine layout, providing very little space, without sacrificing payload or thrust capacity.

Features:

- High acceleration and speeds
- Drive Shaft versions with clamp shaft or plain shaft
- Power transmission by belt
- Moving axis profile
- Complete motor and control packages
- IP 20 rating

Advantages:

- Fixed actuator head for low moving mass
- Integrated ball bearing guide for high bending moments
- Magnetic switch set for contactless position sensing
- Easy to install
- Low maintenance

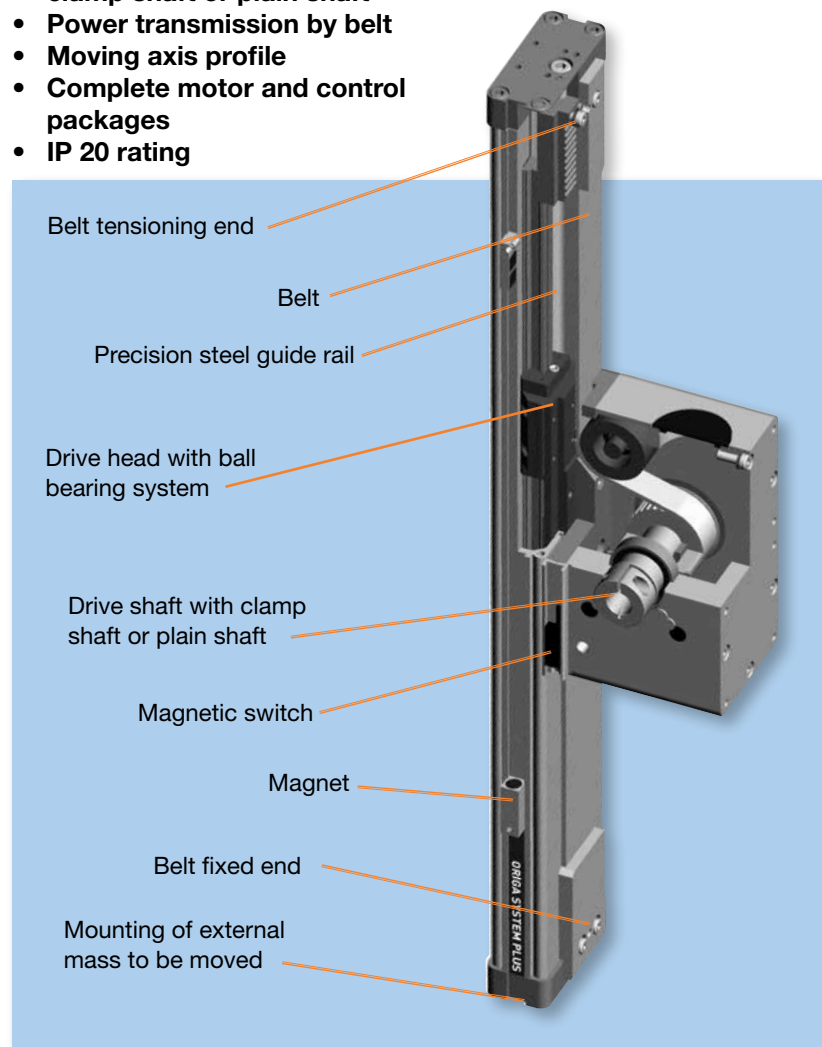

Choose from a wide range of standard options for maximum design flexibility in a pre-assembled system.

Actuator Head Orientation

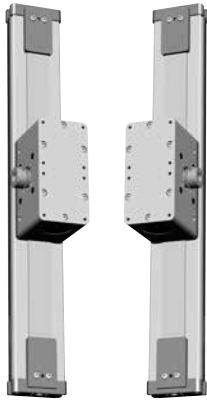

All OSPE..BV actuator heads are standard with an integrated ball bearing guide and are available with either left or right side gearhead/motor mounting.

Drive Shaft Options

Drive shaft with clamp shaft



Drive shaft with both clamp and plain shaft



Drive shaft with plain shaft



Drive shaft with double plain shaft for parallel operation of two Z-axes with an intermediate drive shaft



Drive Head Options

Standard

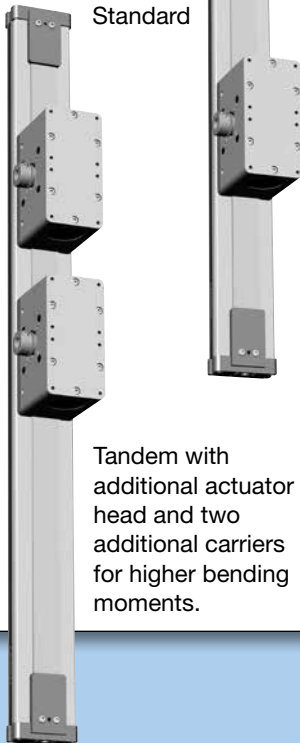

Tandem with additional actuator head and two additional carriers for higher bending moments.

Magnetic Switches Set

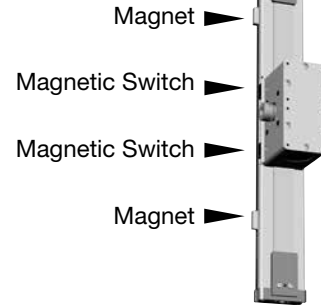

Magnetic switches with connector, mounting rail and magnets for contactless sensing of the end positions. Cable (suitable for cable chain) can be ordered separately in 5 m, 10 m or 15 m length.

Options and Accessories

Information on all OSPE..BV Series options is detailed on the following pages. Simply select all the options needed to solve your application requirements, then order with the actuator using convenient order codes (see last pages of the OSPE..BV section). To order an option separately as an upgrade to an existing system or as a replacement part, use the individual option part numbers provided.



Multi-axis Systems

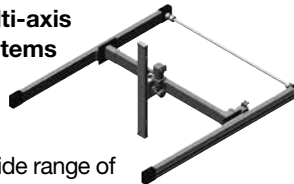

A wide range of adapter plates and intermediate drive shafts simplifies engineering and installation. Please consult factory for your individual system design.

OSPE..BV Fixed Belt-Driven Actuators

Performance Data

Actuator Size			OSPE20BV	OSPE25BV
Travel Distance per Revolution	s_{lin}	mm	108	160
Linear Speed (Max)	v_{max}	m/s	3	5
Acceleration (Max)	a_{max}	m/s ²	20	20
Repeatability		μm	± 50	± 50
Order Stroke (Max)		mm	1,000	1,500
Recommended Permissible Mass (Max)		kg	10	20
Thrust Force (Max)	F_{Amax}	N	650	1,430
		lbs	146	321
Torque on Drive Shaft (Max)	M_{Amax}	Nm	12	38
		in-lb	104	333
Torque* – No Load	RMS	M_0	Nm	0.9
			in-lb	8
	Peak	M_0	Nm	1.1
			in-lb	10
Load** (Max)	F_Y	N	1,600	
		lbs	360	
	F_Z	N	1,600	
		lbs	360	
Bending Moment Load* (Max)	M_X	Nm	20	
		in-lb	177	
	M_Y	Nm	100	
		in-lb	885	
	M_Z	Nm	100	
		in-lb	885	
Thrust Force (Max) FA	N @ Specified Speed	<1 m/s	650	
		<2 m/s	605	
		<3 m/s	450	
		<4 m/s	—	
		<5 m/s	—	
	N @ Specified Stroke	<1 m	650	
		<2 m	605	
		<3 m/s	450	
		<4 m/s	—	
		<5 m/s	—	
Torque (Max) MA	Nm @ Specified Speed	<1 m/s	12	
		<2 m/s	11	
		<3 m/s	8	
		<4 m/s	—	
		<5 m/s	—	
	Nm @ Specified Stroke	<1 m	12	
		<2 m	11	
		<3 m/s	8	
		<4 m/s	—	
		<5 m/s	—	
Inertia				
@ Zero Stroke	J_0	kgmm ²	486	1,695
Per Meter of Stroke	J_{OS}	kgmm ² /m	1,144	2,668
Per 1 kg Moved Mass	J_m	kgmm ² /kg	296	649
Weight				
@ Zero Stroke	m_0	kg	2.8	6.2
Per Meter of Stroke	m_{OS}	kg/m	4.5	7.8
Moved Mass of Carriage	m_C	kg	1.5	2.6
Ambient Temperature Range		°C	-30 to +80	
IP Rating			IP 20	

* For Tandem option double the values listed

** Load and bending moment based on 8000 km performance

Base Unit Dimensions — mm

Drive Shaft Versions:

- Clamp shaft • Plain Shaft • Clamp Shaft with Plain Shaft • Double Plain Shaft

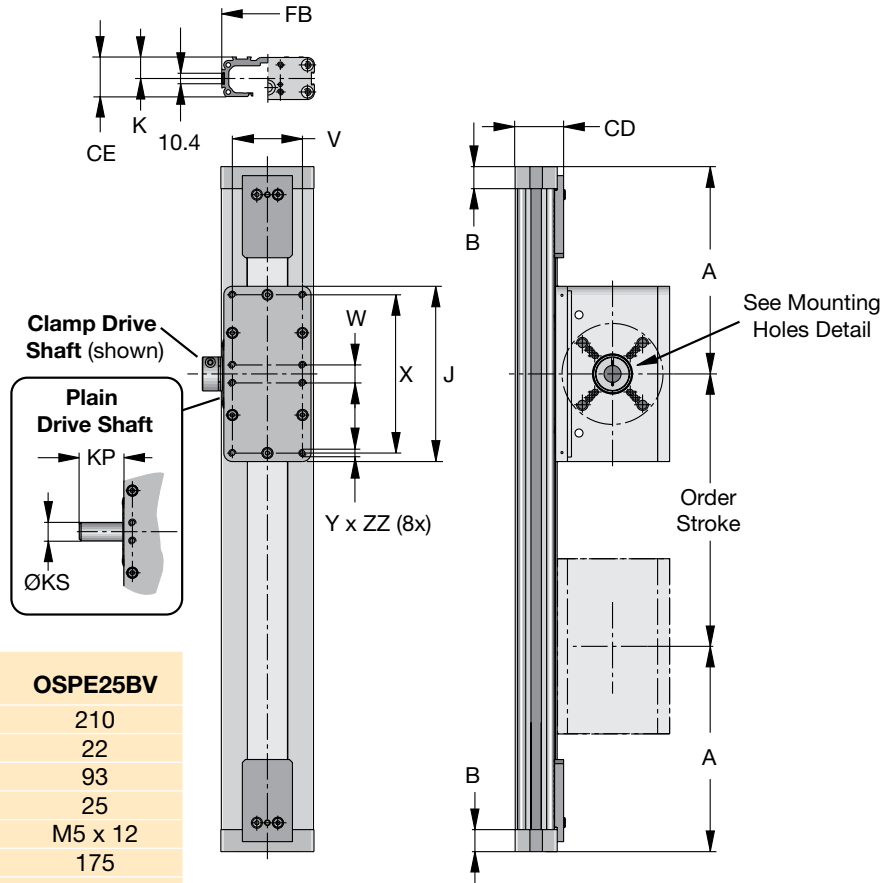
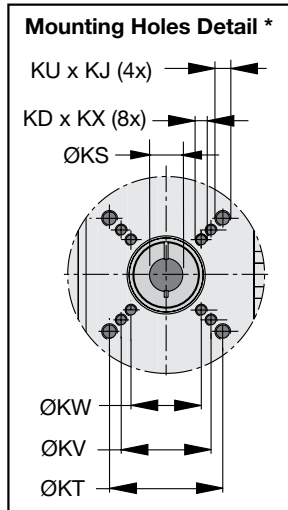

Actuator Size	OSPE20BV	OSPE25BV
A	148	210
B	22	22
C	93	93
E	25	25
G x H	M5 x 12	M5 x 12
J	139	175
K	21	22
M	102	134
S	68	87
V	51	70
W	40	18
X	120	158
Y x ZZ	M6 x 10	M6 x 10
CD	40	49
CE	34	42
CF	123	155
EC	59	72
EF	21	27
FB	73	92
FH	36	40
KD x KX	—	M6 x 16
KF	61	76
KN	27	34
KO	16	22
KP	29	32
KS	12 ^{H7}	16 ^{H7}
KT	47	58
KU x KJ	M6 x 10	M8 x 16
KV	36	46
KW	—	36

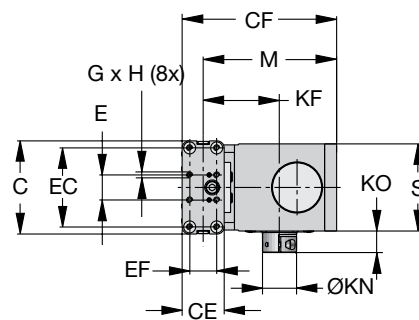

* Mounting holes for motor flange or external planetary gearhead. Drive shaft and motor mounting holes can be located on either side of carriage (see page xx for ordering information on drive shaft options).

OSPE..BV Fixed Belt-Driven Actuators

Order Stroke Dimensions — mm

Standard Drive Head

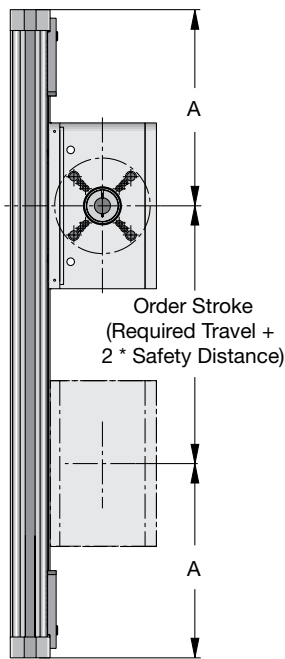

Actuator Size	OSPE20BV	OSPE25BV
A	148	210
KM _{min}	155	225
KM _{rec}	225	275

KM_{min} is the minimum distance between two drive heads possible.
 KM_{rec} is the recommended distance between two drive heads for optimal performance.

Tandem Drive Head

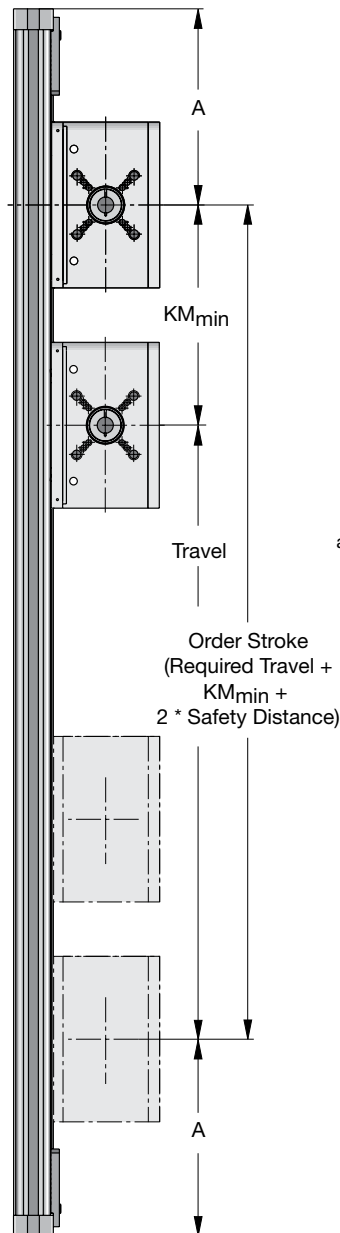

Magnetic Switch Dimensions

The magnetic switch set provides contactless sensing of the end positions. The mounting rail and magnetic switches are mounted on the actuator drive head and the magnets are mounted in the dovetail slot on the profile.

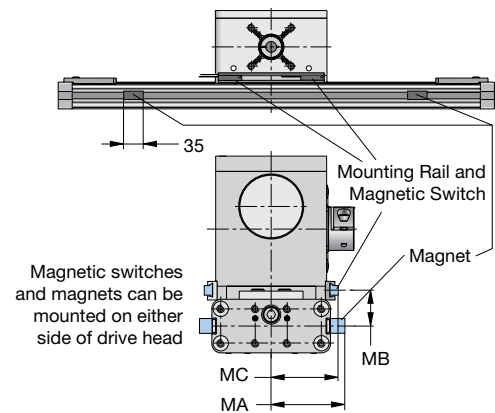

Dimension (mm)

	OSPE20BV	OSPE25BV
MA	46.0	56.0
MB	23.7	26.0
MC	42.3	51.0

Order Stroke Safety Distance:

The mechanical end position should not be used as a mechanical end stop, thus an additional Safety Distance at both ends of travel must be incorporated into the Order Stroke.

The safety distance for servo-driven systems is equivalent to the travel distance per one revolution of the drive shaft.

AC motor-driven systems with VFDs require a larger safety distance than servo systems. For further information and design assistance, please consult factory.

Ordering Information

Select an order code from each of the numbered fields to create a complete OSPE..BV model order number. Include hyphens and non-selective characters as shown in example below.

	①	②	③	④	⑤	⑥	⑦	⑧	⑨						
Order Number Example:	OSPE	20	-	7	0	0	02	-	00000	-	P	00	0	0	0

① **Series**
OSPE Origa System Plus Electromechanical

② **Bore Size**
20 73 mm W x 123.3 mm H
25 93 mm W x 154.5 mm H

③ **Drive Train**
7 Vertical Fixed Belt-Driven Actuator w/Integrated Ball Bearing Guide

④ **Carriage**
0 Standard
1 Tandem (two drive heads for higher actuator stiffness)

⑤ **Drive Shaft Configuration and Orientation** ⁽¹⁾

02 Clamp Clamp shaft* (left)

04 Clamp shaft* (right)

03 Clamp Plain Clamp shaft* (left) with plain shaft for use with intermediate drive shaft for parallel actuator system

05 Plain Clamp Plain Clamp shaft* (right) with plain shaft for use with intermediate drive shaft for parallel actuator system

0A Plain Plain Plain shaft idler unit** (left) for parallel actuator system

0B Plain Plain shaft idler unit** (right) for parallel actuator system

* Consult factory for all gearhead and motor mounting options
 ** Only available with order code 00 "No gearhead mounting kit or motor option" (item ⑧)

⑥ **Order Stroke***
00000 5-digit input (in mm)*

* Maximum standard stroke: OSPE20BV = 1000 mm; OSPE25BV = 1500 mm. For example, to OSPE..V with maximum order stroke, specify 01500. Longer strokes available upon request. Consult factory.

⑦ **Hardware and Cover Strip**
P Standard hardware with Parker gold cover strip

⑧ **Gearhead/Motor Mounting Options**
00 No gearhead mounting kit or motor option
xx Consult factory for all gGearhead and motor mounting options

⑨ **Magnetic Sensor Mounting**
0 No sensor mounting
B 2 pc. N.C., NPN, with M8 connector
E 2 pc. N.C., PNP, with M8 connector

* Extension cable with M8 plug and 5 m cable flying lead cable for Sensor with M8 connector can be ordered separately; use part number 003-2918-01

(1) Drive Shaft Orientation

Drive shaft orientation is determined by viewing the actuator facing the drive head with the belt tensioning end facing up and the end cap for mounting the load facing down.

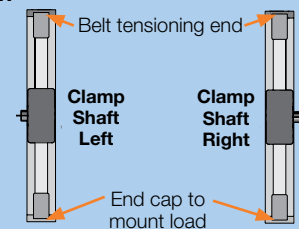

Note:
 Special drive shafts are available – consult factory.

Modular Structural Solutions

High-Strength Aluminum Framing and Components



Parker Industrial Profile Systems (IPS) is a leading value-added manufacturer of high-strength aluminum framing, systems and components. Our focus is on our customer. By offering local inventory, application engineering, fabrication and assembly, and integration of industry leading Parker motion control products, we strive to exceed our customer's expectations in service, quality, delivery, and value.

Typical Applications

- Motion system integration
- Enclosures and guarding
- Machine bases and frames
- Work stations and tables
- Material handling systems
- Lean manufacturing tools
- Cleanroom designs

Benefits

- Extremely short turnaround time from design to completion
- No welding, grinding, cleaning, painting, or distortions
- Eliminates costly traditional manufacturing processes
- Flexibility to re-configure as requirements change

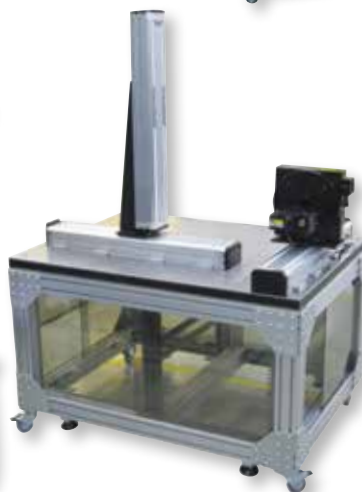

Your Choice to Suit Your Needs

Choose a level of service to suit your needs from a completely assembled structure to a bundle of uncut profiles.



Turnkey Assemblies - Parker IPS offers complete assembled solutions that are designed, custom fabricated, and shipped in as little as seven business days.



Kits - Profiles are cut and machined to order, fasteners and accessories are included based on a parts list, and the entire order is packaged and shipped for final assembly at your location.



Bundles - Our entire product line can be ordered as bundles of uncut or cut-to-length profiles, with packages of fasteners and accessories.

Profiles

Parker Industrial Profile Systems has one of the most comprehensive product offerings in the industry.

- **More than 100+ individual high-strength aluminum profiles**
- **All structural profiles are aircraft grade, high strength, mill-certified with metallurgical properties of 6105-T5**
- **Aesthetically appealing extrusions offer best-in-class rigidity, durability, and hardness**
- **Unique T-slot design for reliable connection and easy modification**
- **Metric sizes range from 20 mm to 160 mm; inch sizes range from 1" to 6"**
- **Extensive range of smooth, grooveless profiles**

Linear Motion Components

- **Roller bearing components**
- **Delrin and UHMW slide bearings**
- **Easy-to-design, do-it-yourself, belt-driven solutions**

Tools and Support

Parker IPS offers the tools needed to design and develop your assembly solution. Download the tools you need at:

www.parkermotion.com/ips

- **Complete selection and specification information on all IPS products available on-line in pdf format**
- **3D CAD files for all available IPS products**

Avoid paying too much for an over-engineered solution, contact our applications team today at 800-333-4932 for quick response and help with designing the best solution.

Fasteners and Accessories

The design of our structural framing fasteners and accessories takes a number of criteria into consideration, including functionality, aesthetics, strength, ease of assembly, and modular, flexible adaptation.



Parker offers a complete line of accessories to provide the right part for your application including:

- **T-slots, end caps, fasteners, and covers**
- **Gussets, plates and brackets**
- **Handles and hinges**
- **Panels, sliding doors and gate hardware**
- **Feet and casters**
- **Work station accessories**
- **Slide blocks and bushings**



Panels & Wire Mesh

Panels and wire mesh are available in full sheets or to specified cut-to-size dimensions. Standard panel choices include:

- **Lexan®**
- **Trespa®**
- **Expanded PVC**
- **PVC coated wire mesh**
- **Aluminum composite**

Specialty panels of any material can be ordered for any project.

Machining Services

Standard machining options include cutting, tapping, drilling, and counter boring. Additional custom machining by our expert machinists ensure that your design is complete and to your exact requirements.

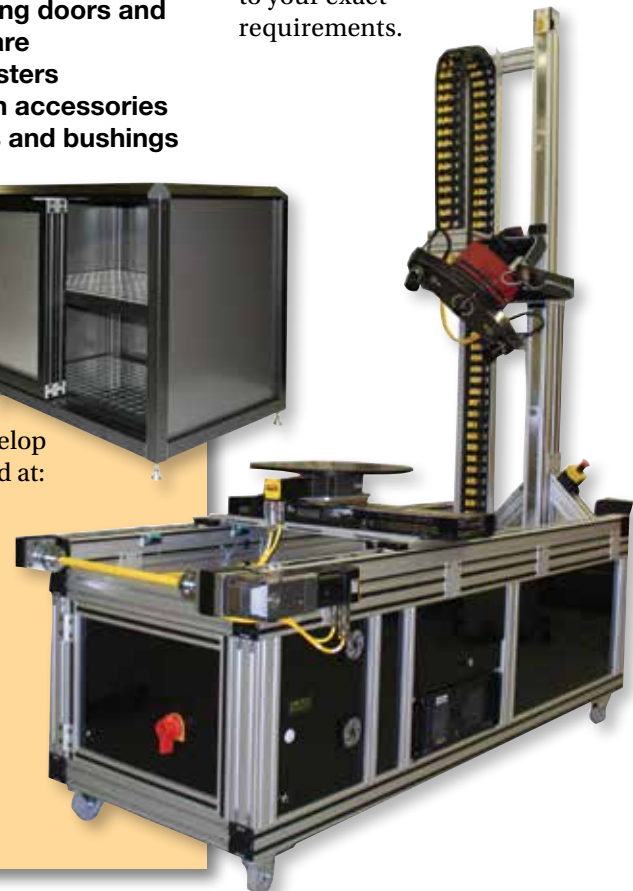

Offer of Sale

The items described in this document and other documents or descriptions provided by Parker, its subsidiaries and its authorized distributors are hereby offered for sale at prices to be established by Parker Hannifin Corporation, its subsidiaries and its authorized distributors. This offer and its acceptance by any customer ("Buyer") shall be governed by all of the following Terms and Conditions. Buyer's order for any such item, when communicated to Parker, its subsidiary or an authorized distributor ("Seller") verbally or in writing, shall constitute acceptance of this offer.

1. Terms and Conditions of Sale: All descriptions, quotations, proposals, offers, acknowledgments, acceptances and sales of Seller's products are subject to and shall be governed exclusively by the terms and conditions stated herein. Buyer's acceptance of any offer to sell is limited to these terms and conditions. Any terms or conditions in addition to, or inconsistent with those stated herein, proposed by Buyer in any acceptance of an offer by Seller, are hereby objected to. No such additional, different or inconsistent terms and conditions shall become part of the contract between, Buyer and Seller unless expressly accepted in writing by Seller. Seller's acceptance of any offer to purchase by Buyer is expressly conditional upon Buyer's assent to all the terms and conditions stated herein, including any terms in addition to, or inconsistent with those contained in Buyer's offer. Acceptance of Seller's products shall in all events constitute such assent.

2. Payment: Payment shall be made by Buyer net 30 days from the date of delivery of the items purchased hereunder. Amounts not timely paid shall bear interest at the maximum rate permitted by law for each month or portion thereof that the Buyer is late in making payment. Any claims by Buyer for omissions or shortages in a shipment shall be waived unless Seller receives notice thereof within 30 days after Buyer's receipt of the shipment.

3. Delivery: Unless otherwise provided on the face hereof, delivery shall be made F.O.B. Seller's plant. Regardless of the method of delivery, however, risk of loss shall pass to Buyer upon Seller's delivery to a carrier. Any delivery dates shown are approximate only and Seller shall have no liability for any delays in delivery.

4. Warranty: Seller warrants that the items sold hereunder shall be free from defects in material or workmanship for a period of 12 months from date of shipment from Parker. THIS WARRANTY COMPRISES THE SOLE AND ENTIRE WARRANTY PERTAINING TO ITEMS PROVIDED HEREUNDER. SELLER MAKES NO OTHER WARRANTY, GUARANTEE, OR REPRESENTATION OF ANY KIND WHATSOEVER. ALL OTHER WARRANTIES, INCLUDING BUT NOT LIMITED TO, MERCHANTABILITY AND FITNESS FOR PURPOSE, WHETHER EXPRESS, IMPLIED, OR ARISING BY OPERATION OF LAW, TRADE USAGE, OR COURSE OF DEALING ARE HEREBY DISCLAIMED. NOTWITHSTANDING THE FOREGOING, THERE ARE NO WARRANTIES WHATSOEVER ON ITEMS BUILT OR ACQUIRED WHOLLY OR PARTIALLY, TO BUYER'S DESIGNS OR SPECIFICATIONS.

5. Limitation of Remedy: SELLER'S LIABILITY ARISING FROM OR IN ANY WAY CONNECTED WITH THE ITEMS SOLD OR THIS CONTRACT SHALL BE LIMITED EXCLUSIVELY TO REPAIR OR REPLACEMENT OF THE ITEMS SOLD OR REFUND OF THE PURCHASE PRICE PAID BY BUYER, AT SELLER'S SOLE OPTION. IN NO EVENT SHALL SELLER BE LIABLE FOR ANY INCIDENTAL, CONSEQUENTIAL OR SPECIAL DAMAGES OF ANY KIND OR NATURE WHATSOEVER, INCLUDING BUT NOT LIMITED TO LOST PROFITS ARISING FROM OR IN ANY WAY CONNECTED WITH THIS AGREEMENT OR ITEMS SOLD HEREUNDER, WHETHER ALLEGED TO ARISE FROM BREACH OF CONTRACT, EXPRESS OR IMPLIED WARRANTY, OR IN TORT, INCLUDING WITHOUT LIMITATION, NEGLIGENCE, FAILURE TO WARN OR STRICT LIABILITY.

6. Changes, Reschedules and Cancellations: Buyers may request to modify the designs or specifications for the items sold hereunder as well as the quantities and delivery dates thereof, or may request to cancel all or part of this order, however, no such requested modification or cancellation shall become part of the contract between Buyer and Seller unless accepted by Seller in a written amendment to this Agreement. Acceptance of any such requested modification of cancellation shall be at Seller's discretion, and shall be upon such terms and conditions as Seller may require.

7. Special Tooling: A tooling charge may be imposed for any special tooling, including without limitation, dies, fixtures, molds and patterns, acquired to manufacture items sold pursuant to this contract. Such special tooling shall be and remain Seller's property notwithstanding payment of any charges by Buyer. In no event will Buyer acquire any interest in apparatus belonging to Seller which is utilized in the manufacture of the items sold hereunder, even if such apparatus has been specially converted or adapted for such manufacture

and not withstanding any charges paid by Buyer. Unless otherwise agreed, Seller shall have the right to alter, discard or otherwise dispose of any special tooling or other property in its sole discretion at any time.

8. Buyer's Property: Any designs, tools, patterns, materials, drawings confidential information or equipment furnished by Buyer, or any other items which become Buyer's property, may be considered obsolete and may be destroyed by Seller after two (2) consecutive years have elapsed without Buyer placing an order for the items which are manufactured using such property. Seller shall not be responsible for any loss or damage to such property while it is in Seller's possession or control.

9. Taxes: Unless otherwise indicated on the face hereof, all prices and charges are exclusive of excise, sales, use, property, occupational or like taxes which may be imposed by any taxing authority upon the manufacture, sale or delivery of the items sold hereunder. If any such taxes must be paid by Seller or if Seller is liable for the collection of such tax, the amount thereof shall be in addition to the amounts for the items sold. Buyer agrees to pay all such taxes or to reimburse Seller therefore upon receipt of its invoice. If Buyer claims exemption from any sales, use or other tax imposed by any taxing authority, Buyer shall save Seller harmless from and against any such tax, together with any interest or penalties thereon which may be assessed if the items are held to be taxable.

10. Indemnity For Infringement of Intellectual Property Rights: Seller shall have no liability for infringement of any patents, trademarks, copyrights, trade dress, trade secrets or similar rights except as provided in this Part 10. Seller will defend and indemnify Buyer against allegations of infringement of U.S. patents, U.S. trademarks, copyrights, trade dress and trade secrets (hereinafter "Intellectual Property Rights"). Seller will defend at its expense and will pay the cost of any settlement or damages awarded in an action brought against Buyer based on an allegation that an item sold pursuant to this contract infringes the Intellectual Property Rights of a third party. Seller's obligation to defend and indemnify Buyer is contingent on Buyer notifying Seller within ten (10) days after Buyer becomes aware of such allegations of infringement, and Seller having sole control over the defense of any allegations or actions including all negotiations for settlement or compromise. If an item sold hereunder is subject to a claim that it infringes the Intellectual Property Rights of a third party, Seller may, at its sole expense and option, procure for Buyer the right to continue using said item, replace or modify said item so as to make it non infringing, or offer to accept return of said item and return the purchase price less a reasonable allowance for depreciation. Notwithstanding the foregoing, Seller shall have no liability for claims of infringement based on information provided by Buyer, or directed to items delivered hereunder for which the designs are specified in whole or part by Buyer, or infringements resulting from the modification, combination or use in a system of any item sold hereunder. The foregoing provisions of this Part 10 shall constitute Seller's sole and exclusive liability and Buyer's sole and exclusive remedy for infringement of Intellectual Property Right. If a claim is based on information provided by Buyer or if the design for an item delivered hereunder is specified in whole or in part by Buyer, Buyer shall defend and indemnify Seller for all costs, expenses or judgments resulting from any claim that such item infringes any patent, trademark, copyright, trade dress, trade secret or any similar right.

11. Force Majeure: Seller does not assume the risk of and shall not be liable for delay or failure to perform any of Seller's obligations by reason of circumstances beyond the reasonable control of Seller (hereinafter "Events of Force Majeure"). Events of Force Majeure shall include without limitation, accidents, acts of God, strikes or labor disputes, acts, laws, rules or regulations of any government or government agency, fires, floods, delays or failures in delivery of carriers or suppliers, shortages of materials and any other cause beyond Seller's control.

12. Entire Agreement/Governing Law: The terms and conditions set forth herein, together with any amendments, modifications and any different terms or conditions expressly accepted by Seller in writing, shall constitute the entire Agreement concerning the items sold, and there are no oral or other representations or agreements which pertain thereto. This Agreement shall be governed in all respects by the law of the State of Ohio. No actions arising out of the sale of the items sold hereunder of this Agreement may be brought by either party more than two (2) years after the cause of action accrues.

WARNING

FAILURE OR IMPROPER SELECTION OR IMPROPER USE OF THE PRODUCTS AND/OR SYSTEMS DESCRIBED HEREIN OR RELATED ITEMS CAN CAUSE DEATH, PERSONAL INJURY AND PROPERTY DAMAGE.

This document and other information from Parker Hannifin Corporation, its subsidiaries and authorized distributors provide product and/or system options for further investigation by users having technical expertise. It is important that you analyze all aspects of your application and review the information concerning the product or system in the current product catalog. Due to the variety of operating conditions and applications for these products or systems, the user, through its own analysis and testing, is solely responsible for making the final selection of the products and systems and assuring that all performance, safety and warning requirements of the application are met.

The products described herein, including without limitation, product features, specifications, designs, availability and pricing, are subject to change by Parker Hannifin Corporation and its subsidiaries at any time without notice.

Extensive Automation Solutions

HMI and Controllers



Superior integration and support for machine control as well as HMI hardware and software.

www.parkermotion.com/em/hmicont

Electric Actuators



Screw, belt-driven, and linear motor actuators for the complete range of industrial applications, offering precise motion and flexibility.

www.parkermotion.com/em/linear

Motors and Drives



Parker's family of innovative servo/stepper motors and drives continues to expand to meet the challenges of new technologies.

www.parkermotion.com/em/motordrive

Linear Actuator



Aluminum and steel pneumatic cylinders, guided cylinders, rodless cylinders, and short stroke thrusters from the industry leader.

www.parkermotion.com/pneu/linear

Rotary Actuators



Industry leader in the design and manufacture of pneumatic rack and pinion, and vane-style rotary actuators.

www.parker.com/pneu/rotary

Vacuum Products and Sensors



Vacuum solutions include a broad range of generators (integrated/inline), cups, and pressure sensors.

www.parker.com/pneu/vacsen

Grippers



Parallel, angular, and three jaw grippers are available in over 1,000 configurations.

www.parker.com/pneu/gripper

Airline Accessories



Airline accessories include silencers, flow controls, and mufflers to round out Parker's pneumatic solution.

www.parker.com/pneu/access

Air Control Valves



Valve technology that meets the most demanding requirements in any industrial application.

www.parker.com/pneu/valve

Air Preparation



Parker, the industry leader in air preparation, offers a complete line of products to ensure clean, dry, oil-free air.

www.parker.com/pneu/airprep

Connectors and Tubing



The most complete line of fluid connectors worldwide will meet virtually any automation application.

www.parker.com/pneu/fc

Structural Automation



More than 150 metric and inch profiles, integral motion components, and accessories for unlimited and flexible configurations. Pre-machined kits or complete assemblies.

www.parker.com/ips

EM Sales Offices

Australia

Parker Hannifin (Australia) Pty Ltd.
9 Carrington Road
Castle Hill NSW 2154
Australia
Tel: +61 (0) 2 9634-7777
Fax: +61 (0) 2 9634 3749

Brazil

Parker Hannifin Ind. Com Ltda.
Av. Lucas Nogueira Garcez 2181
Esperança
12325-900 Jacareí, SP
Tel: 12 3954 5100
Fax: 12 3954 5262
Email: automation.brazil@parker.com

Canada

Parker Hannifin (Canada) Inc.
160 Chisholm Dr
Milton, Ontario L9T 3G9
Tel: 905-693-3000
Fax: 905-876-1958
Email: miltoncustservice@parker.com

China

Parker Hannifin Motion & Control
(Shanghai) Co., Ltd
280 Yunqiao Rd. Jin Qiao Export
Processing Zone
Shanghai 201206, China
Tel: (86-21) 50312525
Fax: (86-21) 64459717

France

Parker SSD Parvex
8 avenue du Lac
B.P. 249
F-21007 Dijon Cedex
Tel: +33 (0) 3 80 42 41 40
Fax: +33 (0) 3 80 42 41 23

Germany

Electricmechanical Europe
Parker Hannifin GmbH & Co KG
Robert-Bosch-Strasse 22
D-77656 Offenburg
Germany
Tel: +49 (0) 781 509 0
Fax: +49 (0) 781 509 98176

India

Parker Hannifin India Pvt. Ltd
Automation Group-SSD Drives Div.
133 & 151 Developed Plots Estate
Perungudi, Chennai 600 096
Tel: 044-4391-0799
Fax: 044-4391-0700

Italy

Parker Hannifin SpA
Via Gounod 1
20092 Cinsello Balsamo
Milano, Italy
Tel: +39 02 361081
Fax: +39 02 36108400

Korea

Parker Hannifin Korea
9th Floor KAMCO Yangjae Tower
949-3 Dogok 1-dong Gangnam-gu
Seoul 135-860, Korea
Tel: 82-2-559-0454
Fax: 82-2-556-8187

Mexico

Parker Hannifin de Mexico
Eje uno Norte No.100
Parque Industrial Toluca 2000
Toluca, CP 50100 México
Tel: 52-722-275-4200
Fax: 52-722-279-0316

Singapore

Parker Hannifin Singapore Pte Ltd
11, Fourth Chin Bee Road
Singapore 619702
Tel: (65) 6887 6300
Fax: (65) 6265 5125/6261 4929

Taiwan

Parker Hannifin Taiwan Co., Ltd
No. 40, Wuchiuan 3rd Road
Wuku Industrial Park
Taipei County, Taiwan 248
ROC
Tel: 886 2 2298 8987
Fax: 886 2 2298 8982

Thailand

Parker Hannifin (Thailand) Co., Ltd.
1265 Rama 9 Road
Suanluang, Bangkok 10250
Thailand
Tel: (66) 2 186 7000
Fax: (66) 2 374 1645

UK

Parker Hannifin Ltd.
Tachbrook Park Drive
Tachbrook Park
Warwick CV34 6TU
Tel: +44 (0) 1926 317970
Fax: +44 (0) 1926 317980

USA

Parker Hannifin Electricmechanical
Automation Division Main Office/
Compumotor/CTC
5500 Business Park Drive
Rohnert Park, CA 94928 USA
Tel: 707-584-7558
800-358-9070
Fax: 707-584-8015
Email: emn_support@parker.com

Parker Hannifin Electricmechanical
Automation Division/Daedal
1140 Sandy Hill Road
Irwin, PA 15642
Tel: 724-861-8200
800-245-6903
Fax: 724-861-3330
Email: ddcat@parker.com

