



Smart Sensing Solutions Since 1954



**C** ULTRASONIC  
**LEAR** ) )  
LABEL SENSOR

ttco.com

800-237-0946 • 813-886-4000



## Ultrasonic CLEAR LABEL Sensor

TRI-TRONICS® introduces the very first **Ultrasonic Clear Label Sensor** with a High Performance Graphic OLED display. The OLED display provides the user with an unprecedented view of the sensor's performance, options, program modes, and helpful simple instructions never before offered in a Clear Label Sensor. Designed into the sensor are all the Ease-of-Use characteristics that have made Tri-Tronics' sensors so well known in the industry.

The Ultrasonic Clear Label Sensor is the answer to what the industry has been asking for...

"a reliable, durable, high quality clear label sensor that provides visual confirmation of proper setup and function..." a simple solution, with the ability to accurately adjust for repeatable and reliable performance.

Now "CONFIDENTLY" walk away from the labeling line, "KNOWING" the throughput is at peak performance and trouble free.



### Features

- OLED Alphanumeric Display
- 10 Bar Graphic Contrast Indicator
- Static and Dynamic Numerical Display
- One button AUTOSSET (Gap Set)
- Tweak-able (Momentary Up/Down Adjustable)
- Available Timers and Delays
- Cable and Connector Version (M12 and M8)
- Removable Gap Plate
- High Speed (200µs)  
(1800'/548M per minute)
- Durable and Robust Housing
- Compatible with Existing Mounting Configurations

### Benefits

- Easy to Set Up
- Highly Accurate and Precise
- Low Maintenance
- Affordable, Low-Cost Option
- Made in USA
- Durable and Reliable

### Applications

- Label Rewinding
- Label Applying
- Clear, Paper, Foil, or Mylar Labels
- Splice Detection
- Fold or Crease Detection

# Applications

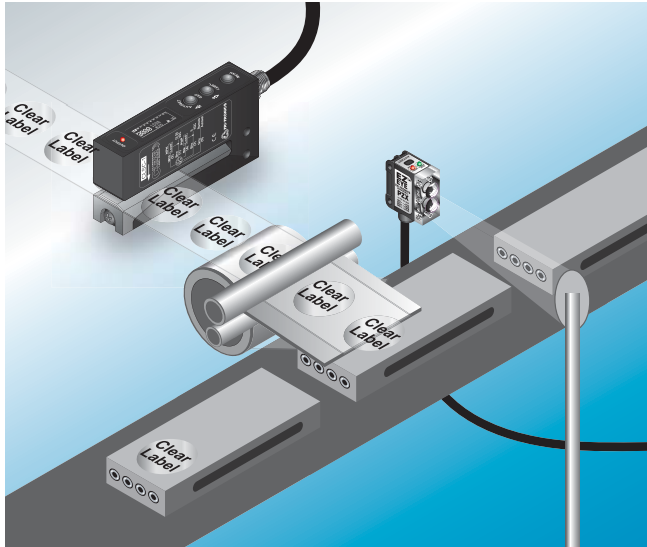

Clear Label Application

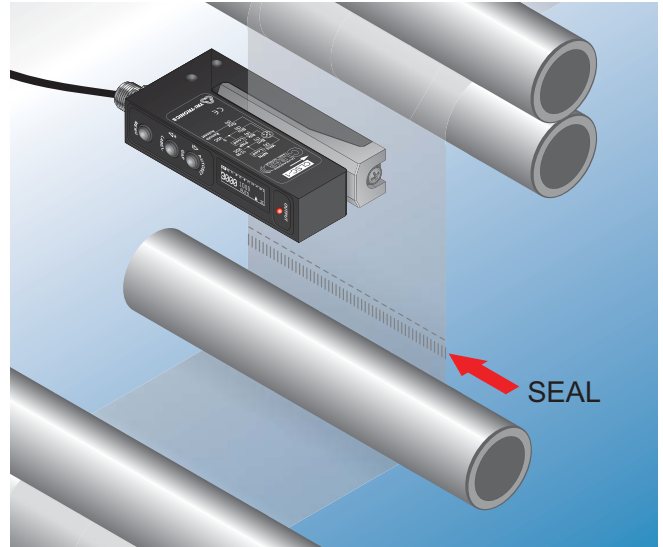

Heat Seal Detection

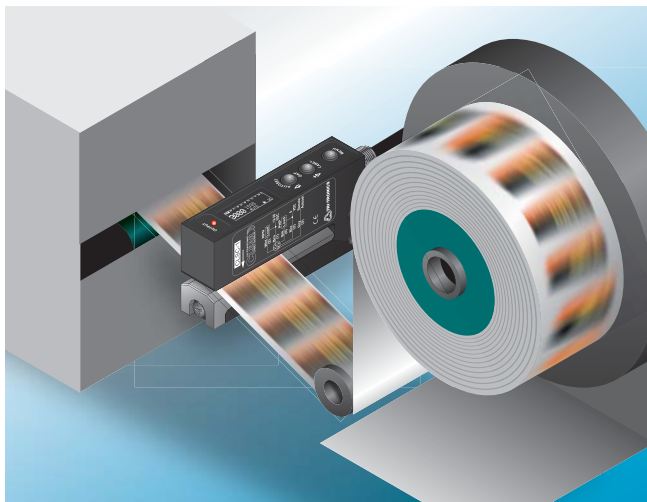

High Speed Rewinding...Clear, Metal Foil, or Paper Labels

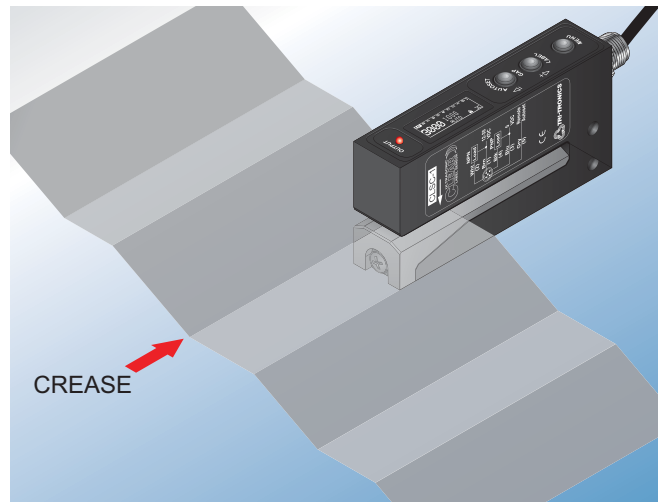

Fold or Crease Detection

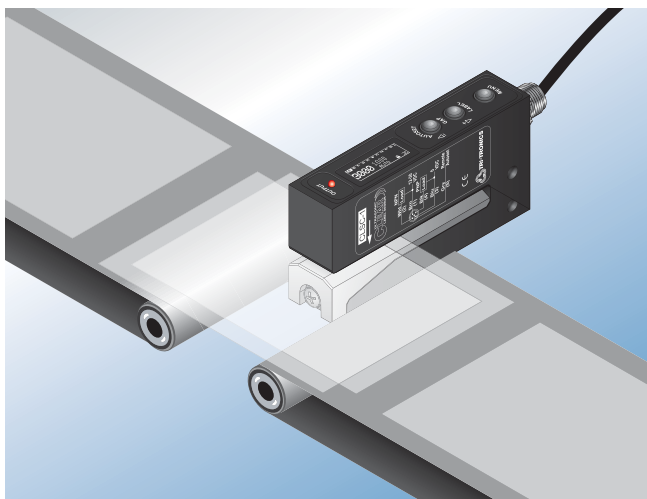

Double Sheet Detection

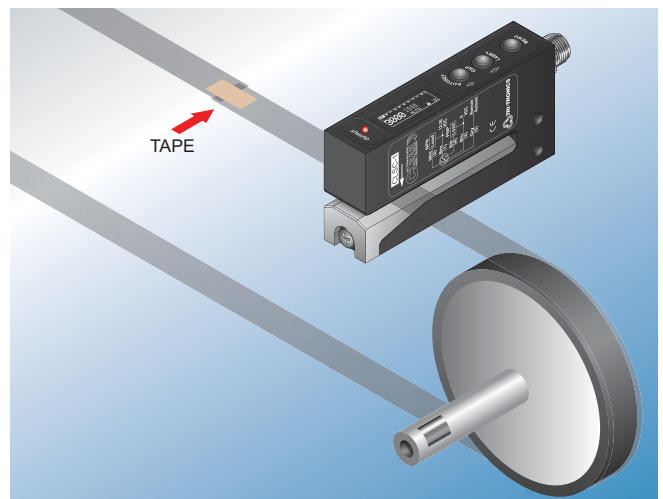

Splice Detection

# Press Menu for Detailed Setup



- ## 1 Initiate Dynamic Set

**Initiate Dynamic Set**  
 Press either the  $\Delta$  or  $\nabla$  button to start a Dynamic Set; pull labels and gaps through sensor; press either the  $\Delta$  or  $\nabla$  button to complete.  
 Sensor exits to run mode and should be setup and ready for operation.
- ## 2 Auto Adjust

**Auto Adjust: On (AUTO)**  
**Auto Adjust: Off**  
 Change from off to on by momentarily pressing either the  $\Delta$  or  $\nabla$  button. The Auto adjust evaluates signal levels and makes automatic adjustments to keep the sensor in optimum response levels.
- ## 3 Output Mode

**Output Mode: Label (I|O)**  
**Output Mode: Gap (□□)**  
 Change from GAP (□□) to LABEL (I|O) by momentarily pressing either the  $\Delta$  or  $\nabla$  button. Output will toggle back and forth in this mode.  
**I|O** = Output on the Label  
**□□** = Output in the Gap
- ## 4 Display Orientation

**Toggle Display Orientation**  
 Momentarily press either the  $\Delta$  or  $\nabla$  button to toggle orientation.
- ## 5 Timer Mode (\*\*Advanced Option)

**Timer Mode: Enabled**

|  |   |  |   |
|--|---|--|---|
| ← PRESS the $\nabla$ button                                      |   | PRESS the $\Delta$ button →                                    |   |
| <b>Timer Mode: Off Delay</b>                                     | <b>Timer Mode: On Delay</b>                           | <b>Timer Mode: One Shot</b>                                    | <b>Timer Mode: Debounce</b>   |
| Off Delay: Outputs stay on for set time after duration of input. | On Delay: Outputs turn on when input exceeds set time | One Shot: Outputs turn on for set time when triggered by input | Debounce: Outputs are stabilized and held in current state for duration of time setting |
- ## 6 Button Lockout

**Button Lockout: Off**  
**Button Lockout: On (🔒)**  
 Momentarily press either the  $\Delta$  or  $\nabla$  button to toggle from Lock (🔒) to Unlock (no symbol). Useful for tamper-free operation.
- ## 7 Quick Reference

|  |  |  |   |
|--|--|--|---|
| ← PRESS the $\nabla$ button                          |  | PRESS the $\Delta$ button →  |   |
| <b>Run Mode</b><br>Top +/- : Scroll Text<br>Run Mode | <b>Dynamic Set</b><br>Tap Menu Button<br>Tap +/- to Start<br>Advance 3+ Labels<br>Tap +/- to End | <b>Remote Input</b><br>Tap 1x : Gap Set<br>Tap 2x : Label Set+<br>Hold : Dynamic Set | <b>Label Set</b><br>Can be used after a Gap/Dyn Set to set max label thickness  |
|  |  | <b>Factory Menu</b><br>Hold Menu on Power Up for more Options<br>Support             | <b>Support</b><br>Tri-Tronics Tampa, FL<br>www.ttco.com/cis<br>support@ttco.com |

Press the the  $\Delta$  button to scroll down through simple setup and options instructions.  
 Press the the  $\nabla$  button to scroll up.
- ## 8 Sensor Scope (\*\*Advanced Option)

  
 This option allows the operator to visually inspect the current setup for repeatability. The sensor scope will also reveal any nominal setup issues or sensitivities to label or gap thickness changes.  
 Momentarily press the  $\Delta$  button to shorten the time between signals. Momentarily press the  $\nabla$  button to lengthen the time between signals.

# Advanced Options

To access Advance Options, press and hold the Menu button during power up.

Press the Menu button to move from screen to screen.

Press either the  $\Delta$  or  $\nabla$  button to select.



## Setup Instructions

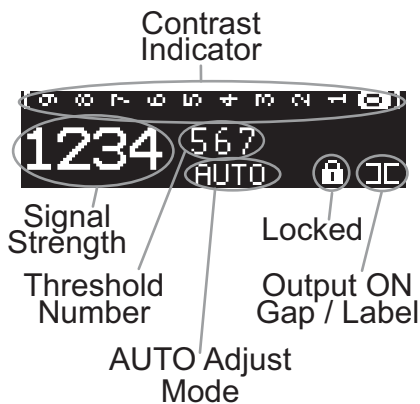

### 1 Factory Reset

**Factory Reset**  
Version:  
Serial:

Press either the  $\Delta$  or  $\nabla$  button to initiate factory reset.

*Note: Advanced Option screen will time out in 5 minutes.*

### 2 Input Mode (-1, -1M8 models only)

**Input Mode:**  
NPN / Sink

Press either the  $\Delta$  or  $\nabla$  button to toggle to PNP / Source or NPN / Sink.

### 3 Timer Features

**Timer Features:**  
Disabled

Press either the  $\Delta$  or  $\nabla$  button to toggle to Enable or Disable.

### 4 Factory Diagnostics/Sensor Scope

**Factory Diag:**  
Disabled

Press either the  $\Delta$  or  $\nabla$  button to toggle to Enable or Disable.

Returns to Main Screen

**Simple Setup Start** ➡ Put the Gap in view, press and hold the AUTOSET/GAP button for two seconds, "Gap Set" will be displayed when complete. This will result in a perfect setup 99% of the time. If you have any false triggers, put the Label in view, push and hold the AUTOSET/LABEL button for two seconds, "Label Set" will be displayed when complete. This two-point setup will create a new threshold setting resulting in a more consistent signal span between web and label.

*Note: Sensor is shipped with a protective plastic covering for the display. Remove protective covering for clearer viewing.*

## Remote Input Signals

Gap Set: Pulse once, 40ms to 400ms.

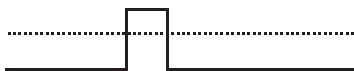

Label Set: Pulse twice, 40ms to 400ms, with 40ms to 400ms idle time between pulses.

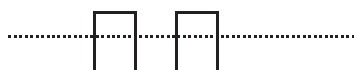

Dynamic Set: Hold Remote Input on for more than 750ms, pull labels and gaps through sensor, release Remote Input line and sensor returns to Run mode.

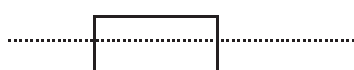

*Note: Waveforms shown correspond to PNP input mode.*

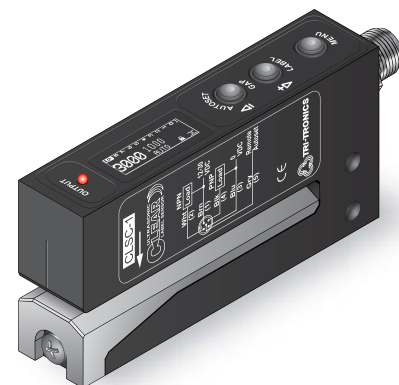

## Initiate Dynamic Set

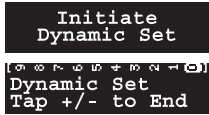

Dynamic Set is a convenient and easy way to set up the CLS sensor. Once initiated, simply pull labels and gaps through the sender receiver transducers and then push the Gap or Label button to complete. This feature is also available via the remote set wire. Dynamic Set is beneficial when holding the gap in place is not easily accomplished, or physical access to the sensor is not practical.

## Auto Adjust

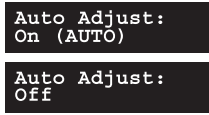

The Auto Adjust feature is helpful in applications with diminishing conditions...such as dirty or dusty environments, or with inconsistent label or web material thickness. This feature bumps up the gain automatically in order to maintain a functional and repeatable contrast between labels and gaps.

## Output Mode

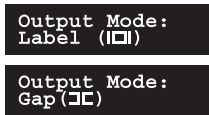

The Output Mode allows the user to decide which is more important to detect...the label or the gap. The leading or trailing edge of labels may be more desirable to receive an output in some applications than others. This option allows the user to make that determination and provides flexibility in real world conditions.

## Display Orientation

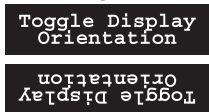

For visual preference, the Display Orientation allows the user to flip the screen for a more user-friendly visibility.

## Timer Mode (\*\*Advanced Option)



The Timer Mode is offered as an Advanced Option. This feature provides users with the option to condition the output specifically for the application requirement.

Off Delay: Extends the Output Time.

On Delay: Extends the Input Time.

One Shot: Provides a defined Output "On" Time.

Debounce: Provides an Anti-Chatter timer.

## Button Lockout



Button Lockout is useful for maintaining a set up without worry. This is tamper-proof, and reassures the continued performance of the sensor and up-time of the production line.

## Quick Reference

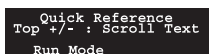

Quick Reference was included as a way to visually instruct through the different set up options. This feature also includes contact information for the factory.

## Sensor Scope (\*\*Advanced Option)



The Sensor Scope is also an Advanced Option and allows the user to visually see how the sensor is detecting the target. Whether the labels or web materials are inconsistent, or noise issues occur occasionally, this feature clearly shows the user exactly where the problems are and how to resolve the issue quickly.

# How to Specify



- 1. Select Sensor:**  
 Ultrasonic Clear Label Sensor
- 2. Select Cable or Connector:**  
 Blank = 6' (1.8m) Cable  
 C = Connector M12, 5-Pin (Standard)
- 3. Select Connector Type:**  
 -1 = Standard M12 Connector (see #2).  
 Includes both NPN and PNP  
 -1M8 = M8, 4-Pin Connector  
 NPN/PNP Software Selectable  
 -1M8LE = Wired like LERC

**Example:** **CLS C -1**

Ultrasonic Clear Label Sensor

Blank = 6' Cable

C = Connector

-1

-1M8

-1M8LE

NOTE: The M12 version is not wired the same as LERRC-M12.

## Features

**OUTPUT INDICATORS**

Red LED illuminates when when outputs are ON

Flashes when short circuit or overload detected

**AUTOSET/GAP  $\Delta$  BUTTON**

1. Push and Hold with gap in view for 2 seconds for AUTOSET.
2. Tap for UP on Contrast Indicator, or reduce threshold.
3. Change settings in MENU options

**AUTOSET/LABEL  $\nabla$  BUTTON**

1. Push and Hold with label in view after GAP AUTOSET on rare occasions when labels have multiple layers.
2. Tap DOWN on Contrast Indicator, or increase threshold.
3. Change settings in MENU options

**OLED NUMERICAL DISPLAY**

1. 1 to 10 bar Contrast Indicator
2. Numerical display for threshold and feedback number
3. Options Status Display: Button Lock or Unlock (🔒); auto adjust on/off (AUTO); output in Gap(□□) or on Label (□□).
4. View Menu Options

**MENU BUTTON**

1. Push and Hold for 1 second to enter Menu Options.
2. Tap to scroll through Menu options.
3. Hold during power up for additional Menu Options; Timers and Factory Diagnostics (or sensor scope).

## Hardware & Accessories

### Micro Cable Selection Guide

#### Yellow Cable Assemblies 4-wire, M8



**GEC-6**  
6' (1.8m) Cable with Connector

**GEC-15**  
15' (4.6m) Cable with Connector



**GEC-25**  
25' (7.62m) Cable with Connector

**RGEC-6**  
6' (1.8m) Right Angle Cable with Connector

**RGEC-15**  
15' (4.6m) Right Angle Cable with Connector



**RGEC-25**  
25' (7.62m) Right Angle Cable with Connector

**GEX-9**  
9' (2.7m) Extension Cable

#### Grey Cable Assemblies 5-wire, M12

**GSEC-6**  
6' (1.8m) Shielded Cable

**GSEC-15**  
15' (4.6m) Shielded Cable

**GSEC-25**  
25' (7.62m) Shielded Cable

**GRSEC-6**  
6' (1.8m) Right Angle Shielded Cable

**GRSEC-15**  
15' (4.6m) Right Angle Shielded Cable

**GRSEC-25**  
25' (7.62m) Right Angle Shielded Cable

**GX-25**  
25' (7.62m) Extension Cable

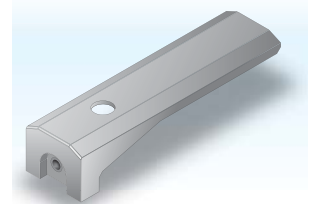

**CLS-GP**  
Gap Plate

# Specifications



## SUPPLY VOLTAGE

- 12 to 30 VDC
- Polarity Protected

*Note: For use in Class 2 Circuits*

## CURRENT REQUIREMENTS

- 95mA @ 12 VDC, 45mA @ 30 VDC

## DIGITAL OUTPUTS

- (1) NPN and (1) PNP open collector output 150mA Max; <2V Residual Voltage
- (*Note: On CLSC-1M8, NPN & PNP are software selectable.*)
- All outputs are continuously short circuit protected

## REMOTE AUTOSET INPUT

- Momentary sinking or sourcing input; 1.2mA max; Software Selectable

## DIAGNOSTIC INDICATORS

- OLED Graphic Display - Includes Contrast Indicator, Numerical Display, Set Point and Trigger Point, and all sensor options and modes.
- Red LED Output Indicator— Illuminates when the sensor's output transistors are "ON".

*Note: If output LED flashes on power up, a short circuit condition exists.*

## PUSHBUTTON CONTROL

- Three (3) push button controls
- Gap (for Gap AUTOSET)
- Label (for multi-layered labels)
- Menu (for accessing Options)

## HYSTERESIS

- Dynamic – adjusted by AUTOSET

## RESPONSE TIME

- 200µs

## REPEATABILITY

- 125µs

## AMBIENT TEMPERATURE

- 4°C to 50°C (39°F to 122°F)

## RUGGED CONSTRUCTION

- Chemical resistant, high impact Aluminum housing
- Waterproof ratings: NEMA 4X, 6P and IP65
- Conforms to heavy industry grade CE requirements

## THRESHOLD SET

- 1-Point, 2-Point, or Dynamic AUTOSET; manually or remotely.

## THRESHOLD ADJUST

- Manual or AUTO Adjust



## OUTPUT TIMERS

- On Delay, Off Delay, One Shot, or Debounce (Advanced Option, software selectable).

## CONNECTOR

- M12 5-Pin, M8 4-Pin, or 6' (1.8m) Shielded Cable

RoHS Compliant  
Product subject to change without notice

## Connections and Dimensions

## Ultrasonic Clear Label Sensor

